

TORKLIFT INTERNATIONAL

OVER 40 YEARS OF INNOVATION, QUALITY, SAFETY.
IMPORTANT OWNER-OPERATOR INSTALLATION INSTRUCTIONS

C3221/C3222

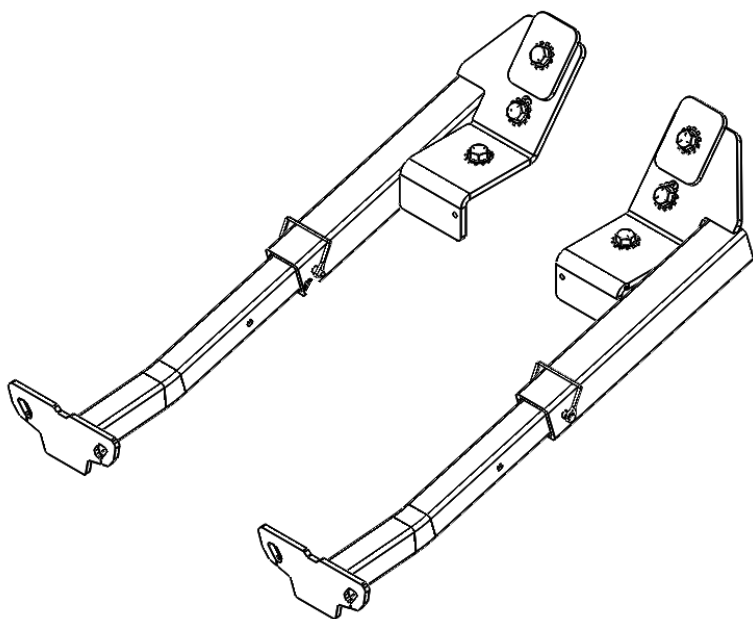

Version (5) BY: DE 2/5/2020

TECH SUPPORT (800) 246-8132

**AFTER INSTALL, PLEASE GIVE
THIS BOOKLET TO YOUR CUSTOMER**

Warnings

Truck Bed and Camper Protection

Torklift **does not** recommend installing your camper on top of a plastic bed liner (or other compressible material such as foam).

These materials can act as a spring, causing increased vertical truck camper movement independent of the vehicle. Plastic bed liners can slide on the truck bed surface, and the truck camper can slide on top of the bed liner. Using a plastic bed liner or similar compressible material will void your warranty and may additionally cause truck bed and/or camper damage.



Minor movement or settling can occur in some incidental harsh driving conditions (on or off-road). A rubber bed mat is recommended to protect the truck bed and camper, but is not a requirement to maintain the Torklift legendary lifetime warranty.

Suspension



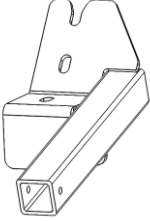
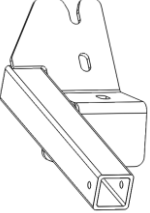
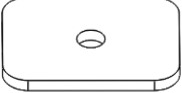
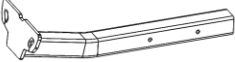
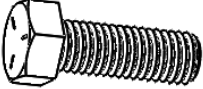
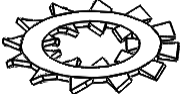

To significantly reduce body roll, sag and sway Torklift strongly recommends the StableLoad. Torklift International StableLoads improve safety, handling, and to help level your truck. More information can be found at (www.Torklift.com/stableload).

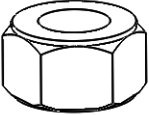
If your truck is additionally equipped with suspension air bags Torklift cautions against over pressurization as this may lead to unsafe vehicle handling characteristics. We have found that airbags used in conjunction with StableLoads have allowed operators to lower air bag pressure by 50% or more. Only pressurize suspension air bags enough to level the truck.

Parts Inventory

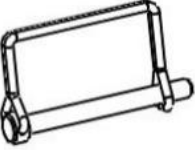
Item Image	Item Description	Item #	Quantity
	Driver Side Receiver	C3221-W1-D Or C3222-W1-D	1
	Passenger Side Receiver	C3221-W1-P Or C3222-W1-P	1
	Clamping Plate	C3221-P2	2
	Tie Down Inserts 17-7/8" – 23° Bent	TD-INS-MS- W13	2
	1/2"-13 x 1-1/2" - Hex Bolt - Grade 8	9960	6
	1/2" Star Washer	4566	6
	1/2" - USS Flat Washer	6039	6
	1/2" - Lock washer	9302	6
	1/2"-13 - Hex Nut - Grade 8	1751	6

Parts Inventory

Item Image	Item Description	Item #	Quantity
	1/4" - Bail Pin	1452	2
	Sticker - Driver Rear Bullet	4649	1
	Sticker - Passenger Rear Bullet	4650	1
	1/2" Bolt Fisher	3818	2

Note: All images are of C3221. C3222 Varies slightly in appearance, however the installation is identical.

Installation Notes

Step 1

- Start by removing the spare tire safety cable on the driver side spring mount. (See Figure 1.1)
- Lower the spare tire to make it easier to access the holes needed to mount the tie down.

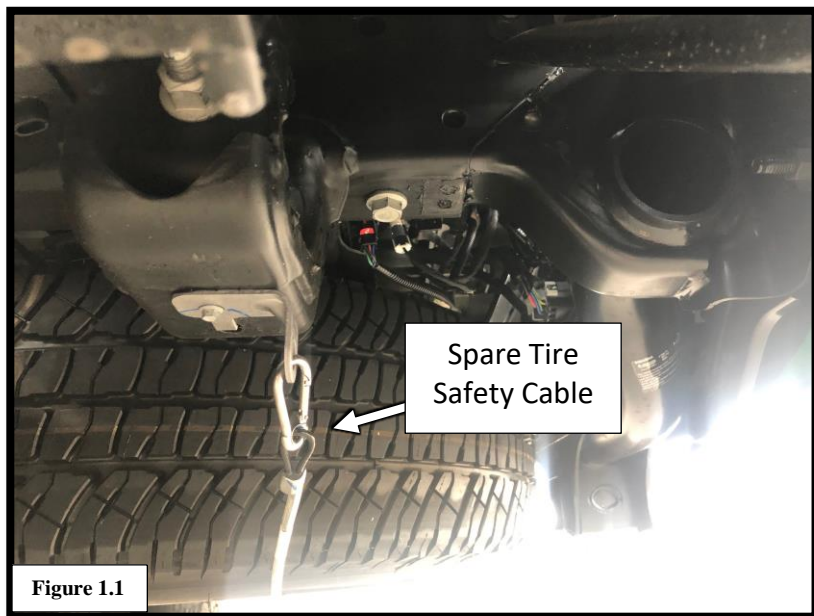

(Some Vehicle May Need Exhaust Hanger Adjustments. For Exhaust Hanger Adjustments Follow the Procedures Below or Skip to Step 2).

- Remove the rear most exhaust hanger from rubber grommet by coating the rubber hanger with WD-40. Use a large open-ended wrench to pry the exhaust from the exhaust hanger. (See Figure 1.2).

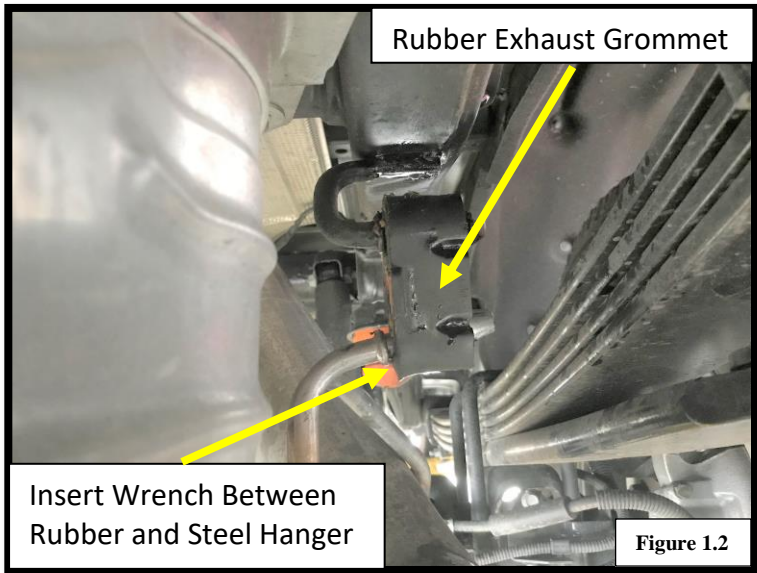

- Use a large wrench to adjust the exhaust hanger down to allow for better clearance, Adjust the hanger upward approximately 1/2"-3/4". (See Figure 1.3).

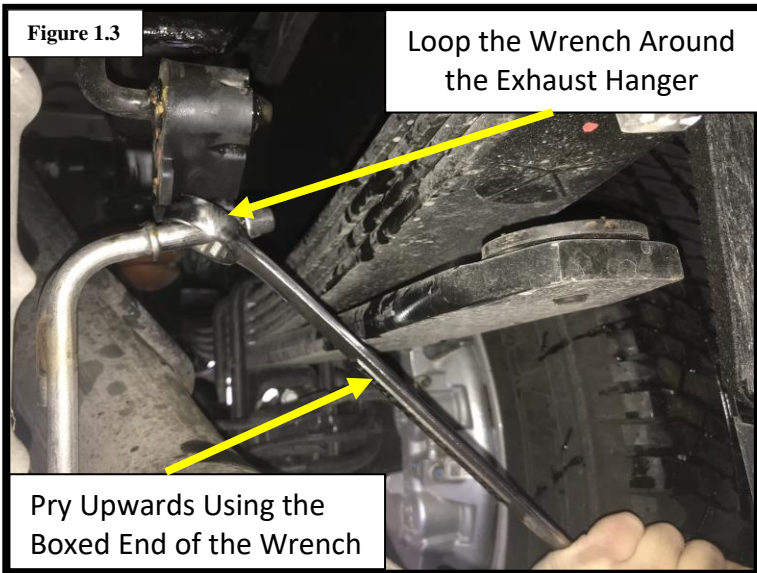

- Reattach the exhaust.

Step 2

- Starting on the driver side of the frame, insert the coiled end of the **1/2" Bolt Fisher** into hole C. Guide the bolt fisher up and out hole A. (See figure 2.1).

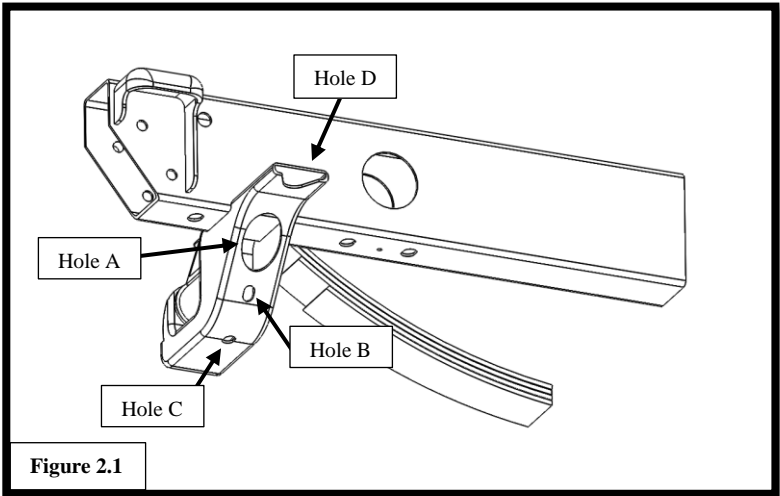

- Slide one **1/2" Star Washer** over the coiled end of the bolt fisher. Attach the coiled end of the **1/2" Bolt Fisher** to a **1/2"-13 x 1-1/2" Hex Bolt**. See figure 2.2 for hardware order.

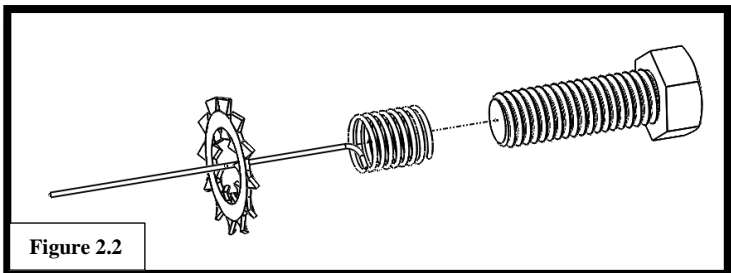

- Pull the non-coiled end of the bolt fisher until the threads of the bolt protrude from hole C. Remove the **1/2" Bolt Fisher**.

Step 3

- Repeat Step 2 for Hole B.
- Leave the hardware inside the frame, with the bolt fisher attached.

Step 4

- Attach the coiled end of the **1/2" bolt fisher** to a **1/2"-13 x 1-1/2" Hex Bolt**. Slide a **1/2" star washer**, and one of the **Clamping Plates** over the non-coiled end of the bolt fisher. See figure 4.1 for hardware order.
- While holding onto the 1/2" bolt attached to the coiled end of the Bolt Fisher, insert the non-coiled end into Hole D and fish it down and out Hole A.
- Slide each component on the bolt fisher one by one through Hole D so each piece fits.
- Pull on the non-coiled end of the bolt fisher to draw the bolt down through the frame. Continue pulling until the **Clamping Plate** sets flat against the outside rim of hole A and the bolt protrudes through the **Clamping Plate**. See figure 2.1 for hole reference.
- Leave the hardware and **Clamping Plate** inside the frame. Leave the **1/2" Bolt Fisher Attached**.

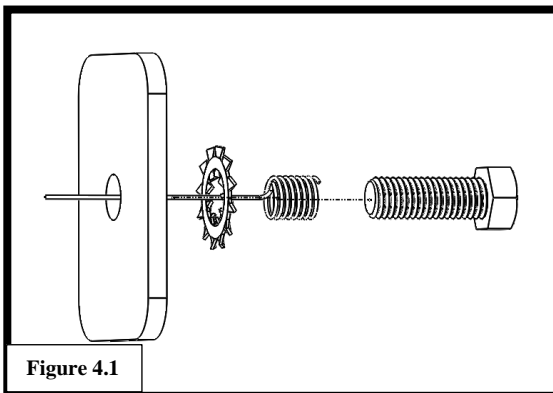

Step 5

- Insert the non-coiled ends of the bolt fishers through the corresponding **Driver Side Receiver** holes. Leave the top two bolts inside the frame.

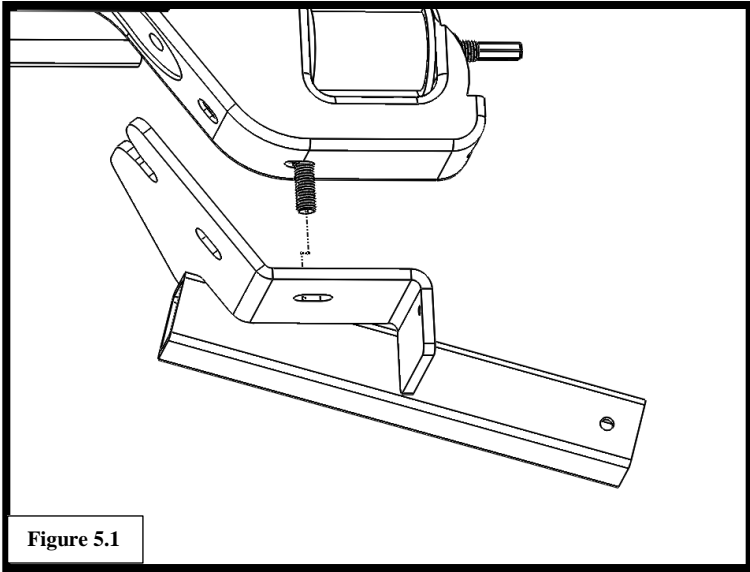

- Raise the Driver Side Receiver into position, being careful not to push the lower bolt back into the frame.
- loosely secure the bolt in hole C with one **1/2" USS Flat Washer**, One **1/2" Lock washer**, and one **1/2"-13 Grade 8 Hex Nut**.
- Gently pull on the ends of each bolt fisher until the bolts protrude from the upper two hole in the **Driver Side Receiver** as shown in Figure 5.2.

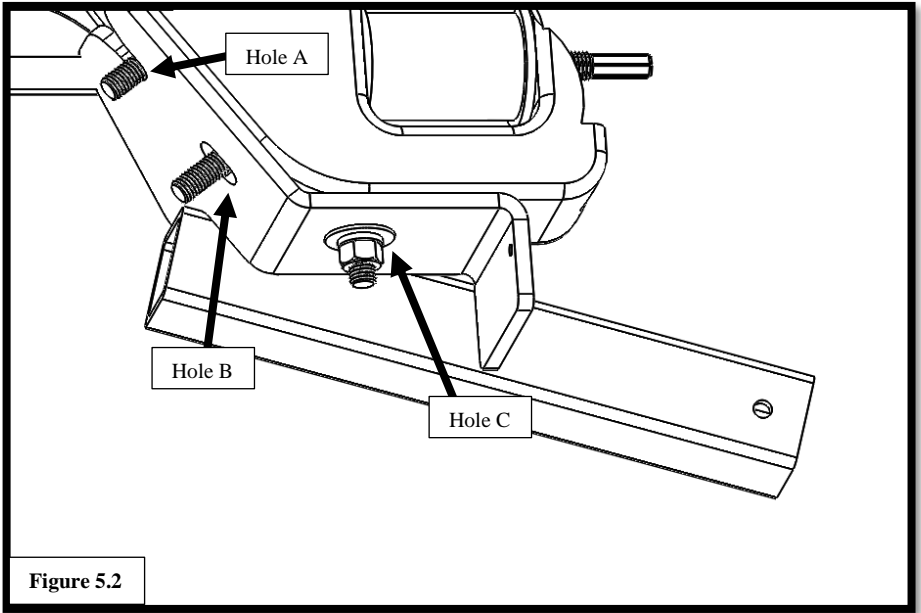

Figure 5.2

Step 6

- Carefully remove the bolt fishers from the remaining two bolts.
- Secure each bolt with one **1/2" USS Flat Washer**, One **1/2" Lock washer**, and one **1/2"-13 Grade 8 Hex Nut**.
- Torque all the 1/2" hardware to 65 ft-lbs.

Step 7

- Repeat the installation process on the passenger side of the vehicle.
- Reattach the spare tire safety cable to the hole in the Driver Side Receiver.

Step 8

- Install a Tie Down Insert into each receiver.
- Use the 1/4" x Bail Pins to pin the Tie Down Inserts into place. Either hole in the insert can be used providing there is sufficient clearance between the turn buckle and vehicle body.
- Install the Driver Front and Passenger Front stickers on the appropriate inserts.
- ***IMPORTANT NOTE: Your tie down inserts are designed to have clearance inside of the receiver. This is to account for road debris, as well as aid in installation and removal. Some rattle may be expected if the inserts are left installed while not under load from the camper.***

Installation is complete!

Torklift International Limited Lifetime Warranty Information

322 Railroad Ave North, Kent, WA 98032

Torklift will require proof of purchase to register, with pictures of any defective product before issuing a replacement. Torklift will not register any product without proof of purchase, which can be faxed, scanned, emailed, or mailed to the information provided below. Torklift warrants its hitches, custom hitch receivers, frame mounted tie downs, turnbuckles, and accessories (excluding wire harnesses which carry a 90 day warranty) from date of purchase against defects in material and workmanship under normal use and service for the ownership life of the original consumer purchaser. All plastic, rubber, and/ or electrical components maintain a warranty of up to one year from the date of the purchase. **ALL COMMERCIAL APPLICATIONS ARE WARRANTED FOR A PERIOD OF 90 DAYS FROM THE DATE OF INSTALLATION/SERVICE.** Torklift will replace **FREE OF CHARGE** any part which proves defective in material or workmanship when presented to Torklift, **TRANSPORTATION CHARGES PREPAID** by purchaser, at the address above. **THIS WARRANTY IS LIMITED TO DEFECTIVE PARTS REPLACEMENT ONLY. LABOR CHARGES AND/OR DAMAGE INCURRED IN INSTALLATION OR REPLACEMENT, AS WELL AS INCIDENTAL AND CONSEQUENTIAL DAMAGES CONNECTED THEREWITH ARE EXCLUDED.** This warranty does not include the finish or paint on our products. Rusting, cracking or peeling of the finish is also excluded. Some states do not allow the exclusion or limitation of incidental or consequential damages, so the above limitation or exclusion may not apply to you. Any damage to Torklift products as a result of misuse, abuse, neglect, accident, improper installation or any use violative of instructions furnished by Torklift or **WHEN USED IN ANY COMMERCIAL APPLICATION WILL VOID THE WARRANTY.** This warranty gives you specific legal rights, and you may also have rights which vary from state to state. With warranty service, you may be able to go to a small claims court, a state court or a federal district court.



TORKLIFT™

INTERNATIONAL

322 Railroad Ave North, Kent, WA 98032

Phone (800) 246-8132 Fax (253) 854-8003

Or visit our website: www.TorkLift.com

Dear Valued Customer,

Thank you for making TorkLift your choice for truck, camper packages and accessories for your vehicle. By choosing TorkLift products, you have chosen a company that has been serving the RV industry for nearly 40 years and whose name has become synonymous with strength, quality and advanced design and installation.

Please take a few moments of your time to complete the Product Registration Warranty Card on the next page. When registering your newly purchased TorkLift products, you can be assured that your contact information is secure and that you and your product are getting the attention and respect that you deserve.

Thank you again for choosing TorkLift quality products.

Register for your lifetime warranty and receive a free Torklift International gift.

To Fax: Send copies of the questionnaire, warranty card and receipt to
253-854-8003

To E-mail: Send copies of the questionnaire, warranty card and receipt to
warranty@torklift.com

To Mail: Send to Torklift International 1901 Fryar Ave Sumner, Wa 98390



OFFICIAL WARRANTY REGISTRATION CARD

322 Railroad Ave North, Kent, WA 98032

PLEASE FILL OUT THIS FORM COMPLETELY AND RETURN TO TORKLIFT WITHIN 30 DAYS OF PURCHASE ACCOMPANIED BY A COPY OF YOUR ORIGINAL RECEIPT

1. PART(S) PURCHASED

TODAY'S DATE: _____

PART #: _____ PART #: _____
PART #: _____ PART #: _____
PART #: _____ PART #: _____

2. PURCHASER INFORMATION

NAME: _____
ADDRESS: _____

CITY: _____ STATE: _____ ZIP / POSTAL CODE: _____
PHONE: (____) _____ - _____ EMAIL: _____

3. TRUCK INFORMATION

YEAR: _____ MAKE: _____
MODEL: _____ BED LENGTH: _____

4. CAMPER INFORMATION

YEAR: _____ MAKE: _____ MODEL: _____

5. DEALER INFORMATION

PURCHASED FROM: _____
ADDRESS: _____

CITY: _____ STATE: _____ ZIP / POSTAL: _____
INSTALLED BY: _____ OWNER ABOVE DEALER ANOTHER DEALER

IF ANOTHER DEALER, WHO: _____