

Installation Manual

PACBRAKE®

www.pacbrake.com 800.663.0096

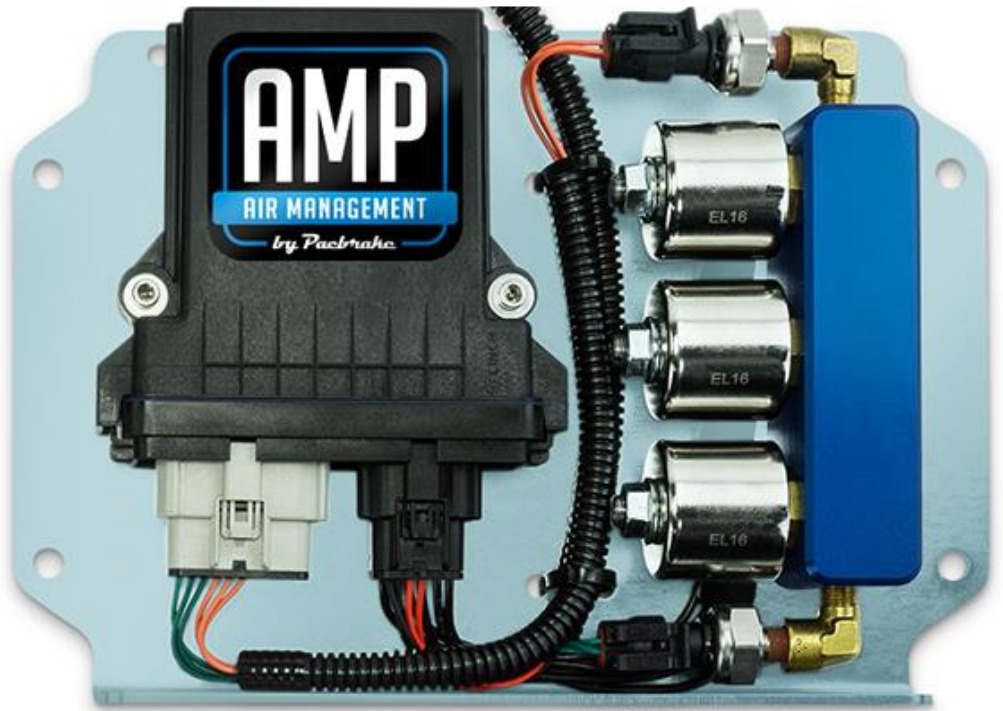

HP10325 KIT

AMP Wireless Air Controls

Take control of your air springs through the AMP Wireless Control application. Requires Air Springs and Onboard Air Systems (sold separately).



Kit Contents

Wireless Control Board	1
Frame Bracket	2
3/8" U-Bolt	2
3/8" Nyloc Nut	4
3/8" Flat Washer	4
5/16" Hex Head Screw	4
5/16" Nyloc Nut	4
5/16" Flat Washer	8
T-Tap, 16-14 AWG	1
Spade Terminal	1
Fuse Holder	1
Fuse, 10A	1
Heat Shrinkable Splice	1
Ring Terminal	1
1/4" Airline	30'
Swivel Air Fitting	2
Tube Cutter	1
Installation Manual	1
Troubleshooting guide	1
Warranty Card	1
AMP Decal	1

System Diagram

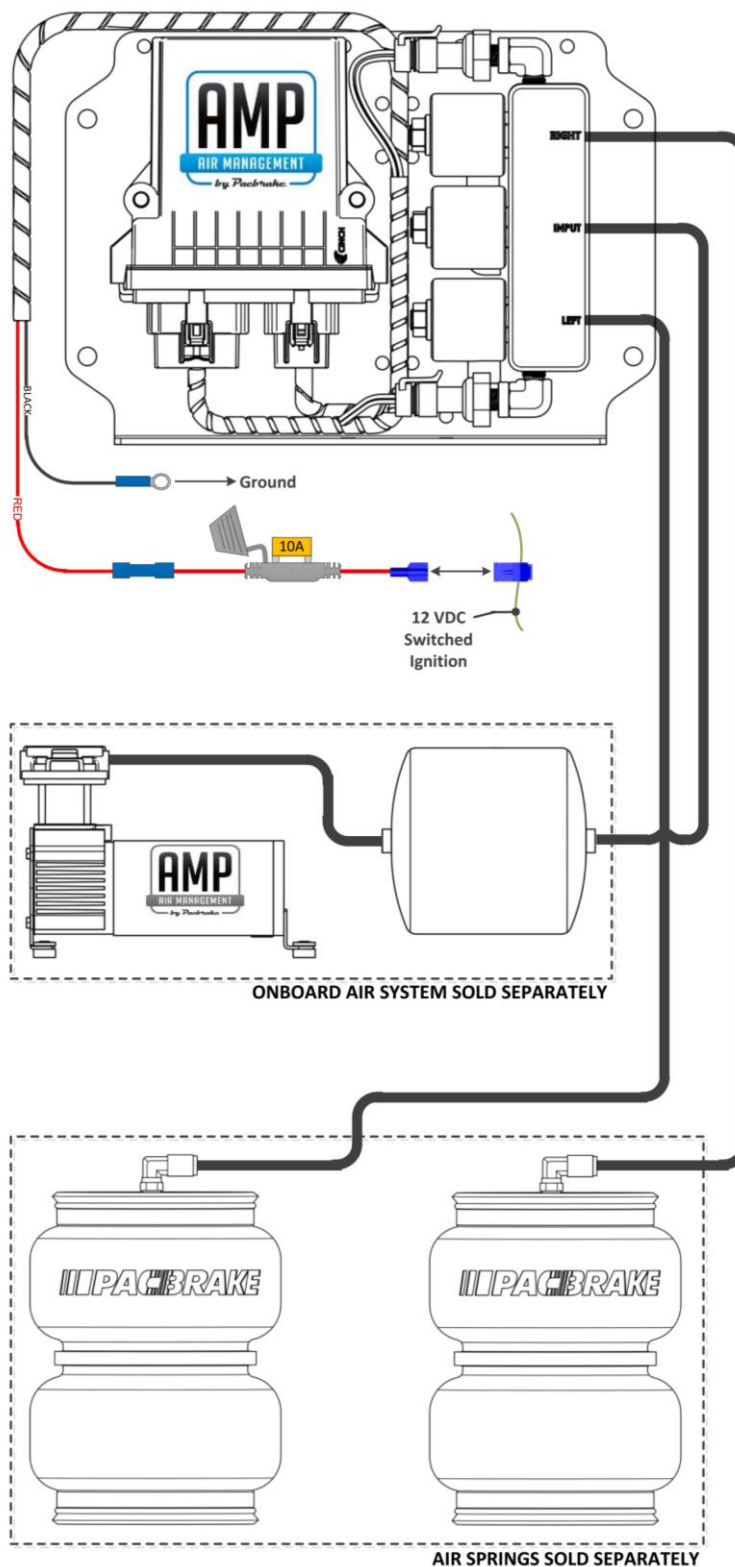

Tools Required

- Wire Strippers
- Terminal Crimper
- Heat Gun or Torch
- Ratchet and Socket Set
- Multi Meter or Test Light
- Torque Wrench

Thank you and congratulations on the purchase of your AMP Wireless Controls kit. Please read the entire installation manual prior to starting the installation to ensure you can complete the install once started.

1 Control Board Installation

- This kit is designed to be installed along the frame rail of pickup trucks, see Figure 1A.
- Check for clearance along the frame rail to ensure that the kit will not interfere with anything once installed. Refer to Figure 1C.
- Fasten the control board to the two frame brackets using the supplied 5/16" cap screws, nuts and washers. Torque the hardware to 17 ft-lbs [23 N.m]. Refer to Figure 1B.



Mount the control board as high as possible on the frame rail and in the orientation shown in Figure 1B.

- Securely install the Control Board Assembly onto the frame rail of the vehicle using 2 U-bolts, 4 flat washers, and 4 nyloc nuts. Refer to Figure 1C.



Check to ensure control board and mounting brackets do not pinch or interfere with vehicle components.

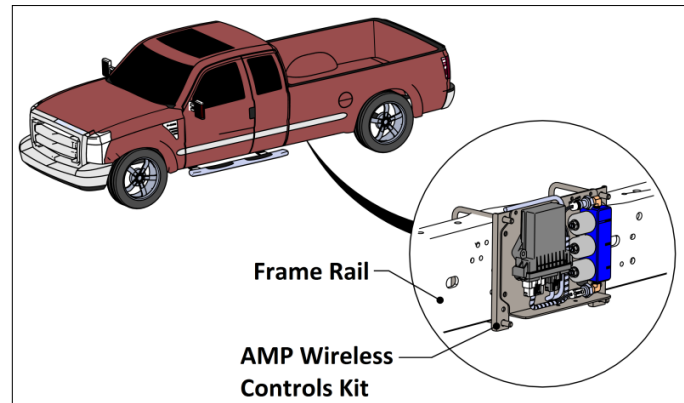

Figure 1A

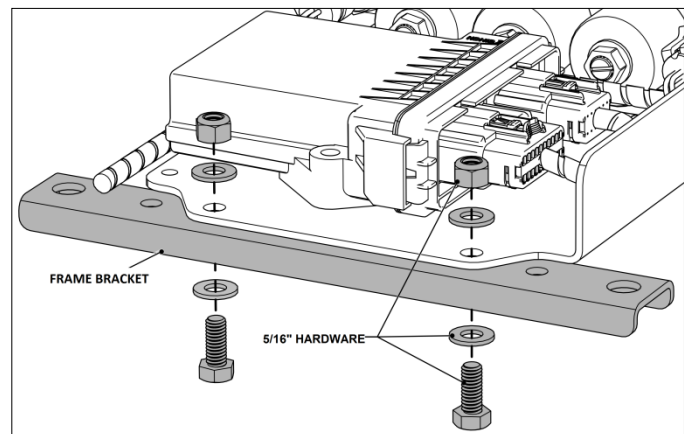

Figure 1B

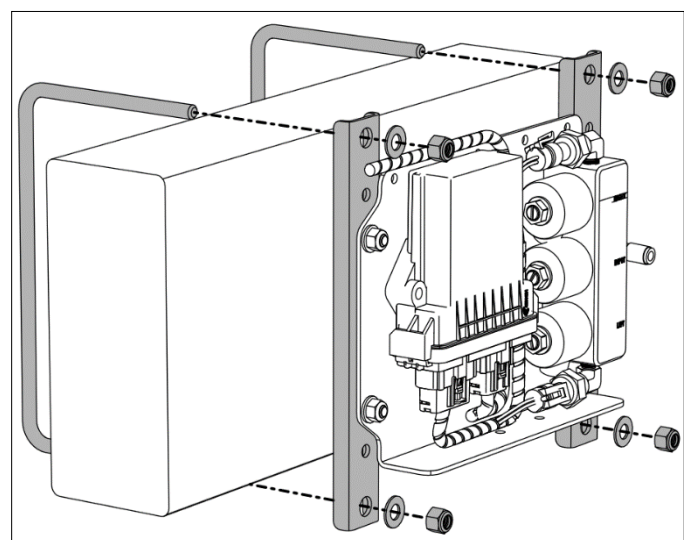

Figure 1C

2 Harness Installation

Refer to the system diagram on page 2 for the following instructions.

- Locate a switched ignition wire at the fuse block in the engine bay
- Ensure the ignition is OFF before proceeding
- Route the red/black harness from the control board to the engine bay. Use the supplied zip ties to secure the harnesses away from heat sources and moving components. Extend/trim the harness as necessary.
- Strip the end of the black wire and crimp the supplied ring terminal to it.
- Connect the ring terminal to the negative terminal of the battery.

If the negative terminal of the battery is not accessible, an external chassis ground may be used provided it has clean contact.

- Use the blue heat shrinkable splice to connect the fuse holder to the red wire.
- Crimp the male spade terminal to the other end of the fuse holder.
- Insert the supplied 10A fuse into the fuse holder.
- Use the blue 16-14 AWG T-tap and crimp it onto a 12VDC switched ignition source, then connect the male spade terminal to the T-Tap.

The T-tap can be crimped onto a constant 12VDC source – giving the user the ability to control their air springs without having to power the truck on. The controller consumes approximately 35-80mA in standby mode, which will slowly discharge the battery.

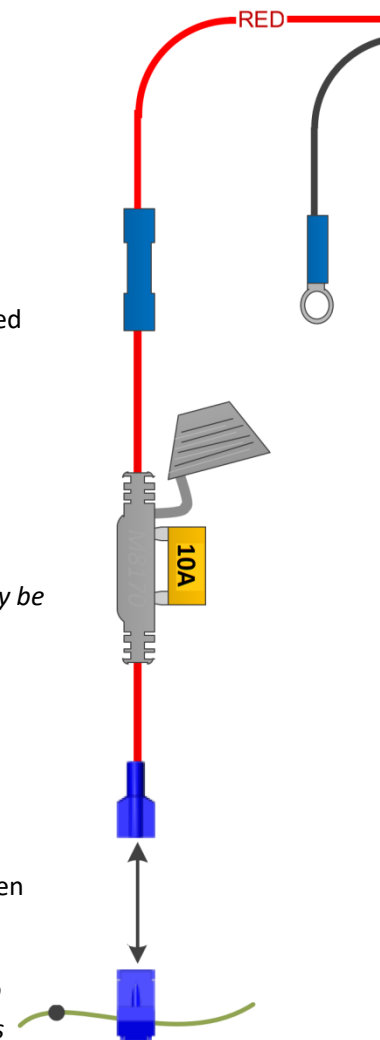

3 Plumbing

Refer to the System Diagram on page 2 for the following instructions.

Use supplied tube cutter to cut airline. Using scissors may distort the line and cause the fitting to leak.

- Connect the input of the solenoid block to the outlet of your onboard air system.
- Connect the inlet of the **DRIVER** side air spring to the **LEFT** port on the solenoid block
- Connect the inlet of the **PASSENGER** side air spring to the **RIGHT** port on the solenoid block.
- Use the supplied zip ties to secure the airlines away from heat sources and moving components

4 Application User Guide

Download the AMP Wireless Air Controls app on Google Play, the App Store, or visit www.pacbrake.com/wireless to download the latest version.

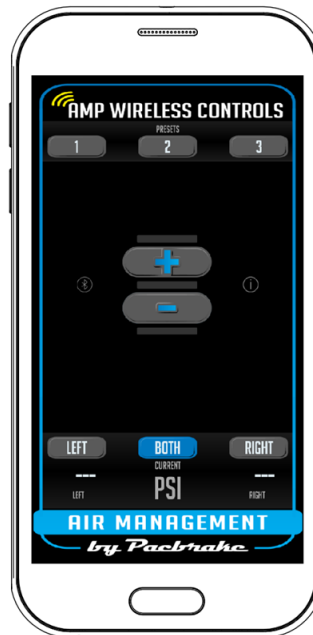

← Presets Tab

← Air Spring Controls Bluetooth Toggle Help Button

← Air Spring Selection Pressure Indicator

Once all installation has been completed, the system is ready to be paired with your mobile device.

4.1 Pairing/Connecting the Controller with an Android Device

- Switch vehicle to ignition power or idle engine to power on controller
- Turn on Bluetooth and Location services on your device
- In system options, open the Bluetooth page
- Refresh and search for the controller with name containing **“PACBRAKE AMP”**
- Select the controller for pairing – if successful, the Wireless AMP controller will be added to the list of paired devices on your mobile device.
- Open the AMP Wireless Controls app. The Bluetooth toggle will illuminate to show if your device has successfully connected to the controller on the AMP Wireless Controls kit.

4.2 Pairing/Connecting to Controller with an iPhone™

- Ensure that Bluetooth and Location services are turned on
- Open the AMP Wireless Controls app. The Bluetooth toggle will illuminate to show that your device has successfully connected to the controller on the AMP Wireless Controls kit.

NOTE: If multiple PACBRAKE AMP devices are nearby, a window will display to select a controller for connection.



4.3 Air Spring Inflation/Deflation

- Press and hold the **Inflation** or **Deflation** button to adjust the pressure in the air springs.
- Use the Air Spring Selection tab to select which air spring to inflate/deflate.



Pacbrake does not limit the minimum or maximum pressure in your air springs. Inflate your air springs according to your air spring manufacturer's guidelines.

4.4 Presets Tab

- Use the **Presets Tab** to save pressure presets.
- Press and hold one of the preset buttons to save the current pressure value as a preset. A message on the bottom of the screen will indicate that the preset has been saved.
- Use these presets anytime to quickly adjust to the desired pressure.

4.5 Bluetooth Toggle

- The **Bluetooth Toggle** illuminates when it has successfully connected to the wireless controller.
- Tap the Bluetooth toggle to manually connect or disconnect from the controller.

Note: The app automatically connects to the controller on startup.

4.6 Air Spring Selection

- Select which air spring to inflate/deflate by tapping on the **Left**, **Both** or **Right** button.

4.7 Pressure Indicator

- The Pressure Indicator shows the pressure of each air spring with an accuracy of $\pm 5\%$ over the entire range.
- The presets allow for rapid adjustment to the desired pressure (± 1 PSI)

5 Leak Testing

- Inflate both air springs to 90 PSI and wait for the pressure readings on the application to stabilize. Allow this pressure to remain in the system for a few minutes and ensure that it is not dropping. If the pressure is slowly decreasing over several minutes, use soapy water on all airline connections to detect any air leaks. Repair as necessary and retest.
- Inflate the air springs to a predetermined value, and on the following day recheck the pressure. If one or both the air springs have lost pressure, an air leak is present. The leak must be repaired, and then retested until no leaks exist.

Congratulations! You have completed the installation. Proceed to the following page for warranty information and operating guidelines.



6 Warranty

To be eligible for warranty, owner must submit their warranty card or register online within 30 days of purchase date. Refer to the attached Warranty Sheet for more information

Operating your vehicle with Pacbrake air suspension

Pacbrake air springs have minimum and maximum pressure requirements. Never operate your vehicle with less than 10 PSI in the air spring and never inflate the air springs over 100 PSI. Staying within the pressure limit will ensure maximum air spring life. Failure in doing so may void the warranty. Check the air pressure in the air springs daily for the first couple of days to ensure a leak does not develop. The air springs are designed to maintain the vehicles stock ride height with a load. Do not use the air springs as a means to lift the vehicle with no load. A rough ride may result.

Servicing your vehicle with Pacbrake air suspension

When lifting the vehicle with a floor jack or hoist on the frame, never allow the air spring to limit the travel of the axle. Try to always jack the vehicle on the axle. Suspending the axle with the air spring limiting the axle travel will damage the air spring and void the air spring warranty.

Disclaimer

Driving while distracted can result in a loss of vehicle control that may lead to an accident, severe personal injury, and death. The driver's primary responsibility is in the safe and legal operation of a vehicle, and use of any handheld devices, other equipment, or vehicle systems which take the driver's eyes, attention and focus away from the safe operation of a vehicle or which are not permissible by law should never be used during operation of the vehicle.

Legal

- Apple and the Apple logo are trademarks of Apple Inc., registered in the U.S. and other countries. App Store is a service mark of Apple Inc., registered in the U.S. and other countries.
- Google Play and the Google Play logo are trademarks of Google LLC
- Android is a trademark of Google LLC
- The Android robot is reproduced or modified from work created and shared by Google and used according to terms described in the Creative Commons 3.0 Attribution License.



FCC Regulatory Approval

Contains Transmitter Module FCC ID: A8TBM70ABCDEFGH

This equipment has been tested and found to comply with the limits for a Class B digital device, pursuant to part 15 of the FCC Rules. These limits are designed to provide reasonable protection against harmful interference in a residential installation. This equipment generates, uses, and can radiate radio frequency energy, and if not installed and used in accordance with the instructions, may cause harmful interference to radio communications. However, there is no guarantee that interference will not occur in a particular installation. If this equipment does cause harmful interference to radio or television reception, which can be determined by turning the equipment off and on, the user is encouraged to try to correct the interference by one or more of the following measures:

- Reorient or relocate the receiving antenna.
- Increase the separation between the equipment and receiver.
- Connect the equipment into an outlet on a circuit different from that to which the receiver is connected.
- Consult the dealer or an experienced radio/TV technician for help.

IC Regulatory Approval

Contains transmitter module IC: 12246A-BM70BLES1F2

This device complies with Industry Canada license-exempt RSS standard(s). Operation is subject to the following two conditions:

- (1) This device may not cause interference, and
- (2) This device must accept any interference, including interference that may cause undesired operation of the device.

Le présent appareil est conforme aux CNR d'Industrie Canada applicables aux appareils radio exempts de licence. L'exploitation est autorisée aux deux conditions suivantes:

- (1) l'appareil ne doit pas produire de brouillage, et
- (2) l'utilisateur de l'appareil doit accepter tout brouillage radioélectrique subi, même si le brouillage est susceptible d'en compromettre le fonctionnement.



CUSTOMER SERVICE HOURS

MONDAY TO FRIDAY FROM 6:00 AM TO 4:30 PM PST

BUSINESS HOURS OF OPERATION

MONDAY TO FRIDAY FROM 7:30 AM TO 4:00 PM PST

CORPORATE HEADQUARTERS / R&D CENTER

19594 96TH AVENUE

SURREY, BRITISH COLUMBIA



ISO 9001
QMI-SAI Global

