



## **INSTALLATION INSTRUCTIONS**

**BULL BAR**

**2011-15 CHEVY SILVERADO/GMC SIERRA 2500/3500**

**PART #35-4013;B35-4013;B35-4013;P35-4013**

**PARTS LIST:**

1	3in Bull Bar Assembly	4	12mm x 32mm OD x 3mm Flat Washer
1	Driver/left Frame Bracket	4	12-1.75mm Nylon Lock Nut
1	Passenger/Right Frame Bracket	8	10-1.5mm x 30mm Hex Bolt
1	Driver/left Bull Bar Mounting Bracket	16	10mm x 27mm OD x 3mm Flat Washer
1	Passenger/right Bull Bar Mounting Bracket	8	10-1.5mm Nylon Locknut
4	12-1.75mm x 35mm Bolt Plates		

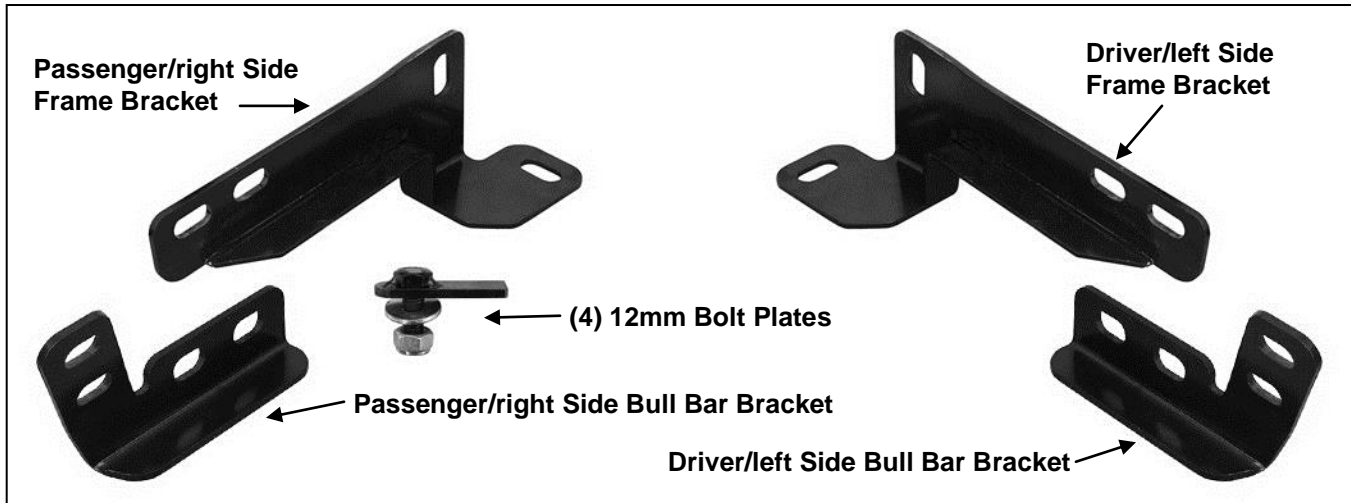

**PROCEDURE:**

- 1. REMOVE CONTENTS FROM BOX. VERIFY ALL PARTS ARE PRESENT. READ INSTRUCTIONS CAREFULLY BEFORE STARTING INSTALLATION. CUTTING MAY BE REQUIRED. INSTALLATION MAY INTERFERE WITH BUMPER MOUNTED PARKING SENSORS.**
- 2. NOTE:** It may be necessary to remove/relocate front license plate and license plate bracket. It is not required, but strongly recommended. If local/state law requires a front license plate, license plate relocation kit is available.
- Starting at the driver side, remove the factory tow hook if equipped, **(Figures 1A & 1B)**. **NOTE:** This Bull Bar is not compatible with the factory tow hooks and they will not be reinstalled. **IMPORTANT:** On some models, with and without tow hooks, the pocket in the plastic bumper may need to be cut out, **(Figure 1A)**. Use a sharp knife or hacksaw blade and carefully cut out the pocket to clear the Bull Bar Brackets. Only cut enough to clear the Brackets.
- Insert (1) 12mm Bolt Plate, **(Figure 3A)**, into the end of the frame channel, **(Figure 2)**, and out through the hole in the bottom of the frame. Insert a second Bolt Plate into the frame and out the hole (for tow hook bolt) through the outer side of the frame, **(Figure 3B)**.
- Select the driver side Frame Bracket. Refer to illustration above for bracket configuration. Position the Frame Bracket onto the outside of the frame channel, **(Figure 4)**, and over the (2) Bolt Plates. Secure the Bracket to the frame and Bolt Plates with (2) 12mm Flat Washers and (2) 12mm Nylon Lock Nuts. Leave hardware loose at this time.
- Next, select the driver side Bull Bar Mounting Bracket. Loosely attach the Bull Bar Bracket to the inside of the Frame Bracket with the included (2) 10mm x 30mm Hex Bolts, (4) 10mm Flat Washers and (2) 10mm Nylon Lock Nuts, **(Figure 5)**. **NOTE:** On some models, it may be possible or simpler to bolt the Frame and Mounting Brackets together first and install as one piece. Do not fully tighten hardware.
- Repeat **Steps 3—6** for passenger side Frame and Mounting Bracket installation.
- With assistance, position the Bull Bar assembly up to the outside of the Mounting Brackets. Attach the Bull Bar to the Brackets with the included (2) 10mm x 30mm Hex Bolts, (4) 10mm Flat Washers and (2) 10mm Nylon Lock Nuts, **(Figure 6)**.
- Level and adjust the Bull Bar and tighten all hardware.
- Do periodic inspections to the installation to make sure that all hardware is secure and tight.

To protect your investment, wax this product after installing. Regular waxing is recommended to add a protective layer over the finish. Do not use any type of polish or wax that may contain abrasives that could damage the finish.

**For stainless steel:** Aluminum polish may be used to polish small scratches and scuffs on the finish. Mild soap may be used also to clean the Bull Bar.

**For gloss black finishes:** Mild soap may be used to clean the Bull Bar.

### Driver Side Installation Pictured

Remove the factory tow hook and hardware. Tow hook will not be reinstalled



Fig 1A

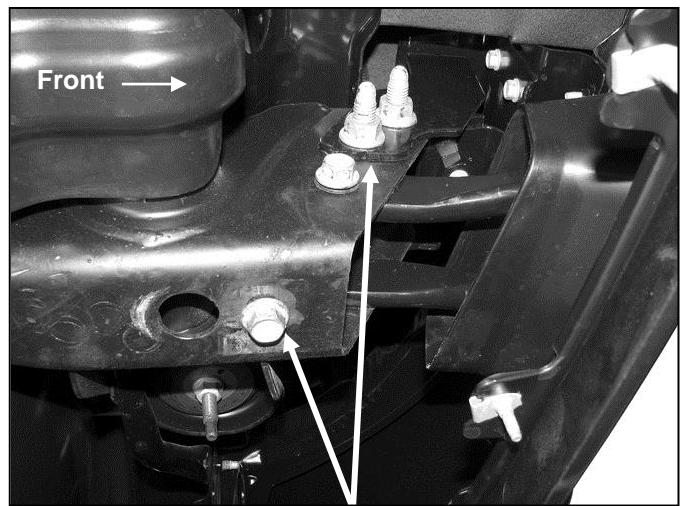
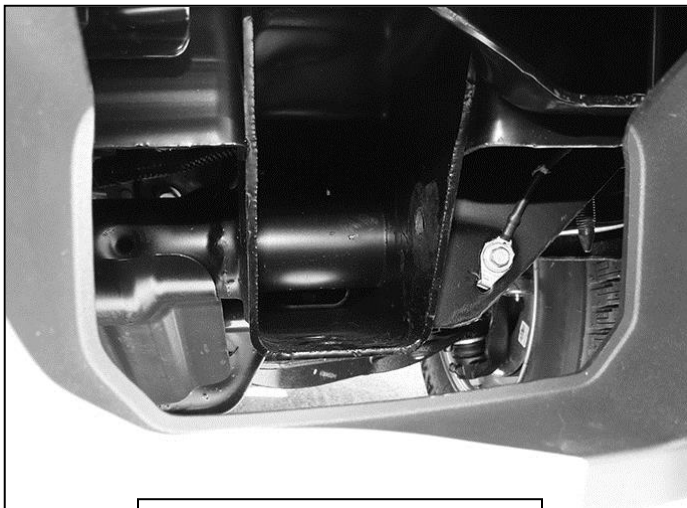

Fig 1B) Remove the tow hook and hardware, (Driver/left tow hook pictured from below bumper)



(Fig 2) Open end of driver/left side frame channel pictured



(Fig 3A) 12mm Bolt Plate with hardware

### Driver Side Installation Pictured

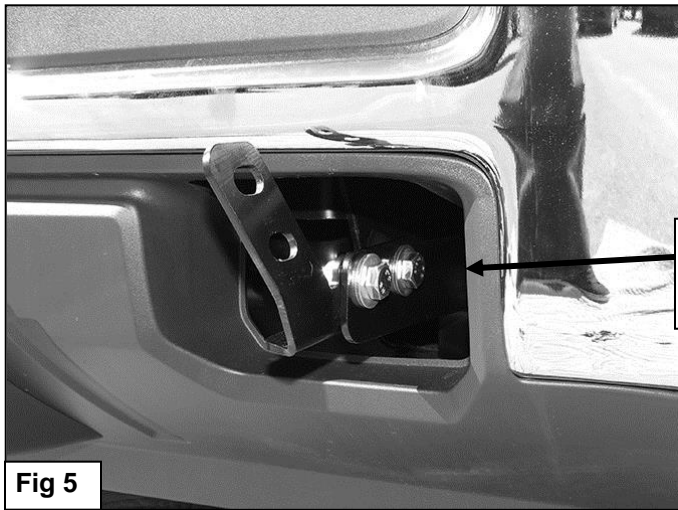
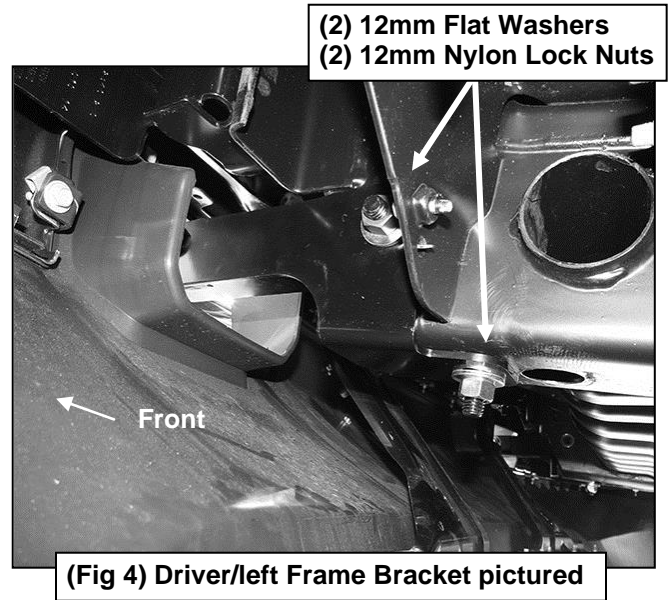
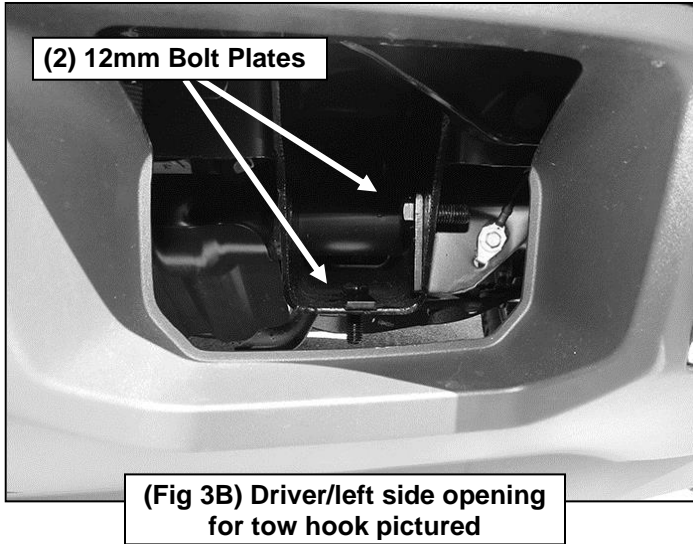

(2) 10mm x 30mm Hex Bolts  
(4) 10mm Flat Washers  
(2) 10mm Nylon Lock Nuts

