



Doing Our Best to Provide You the Best

HJ26330, Rev 0
8/19

5TH WHEEL HITCH

6330 13K Autoslide

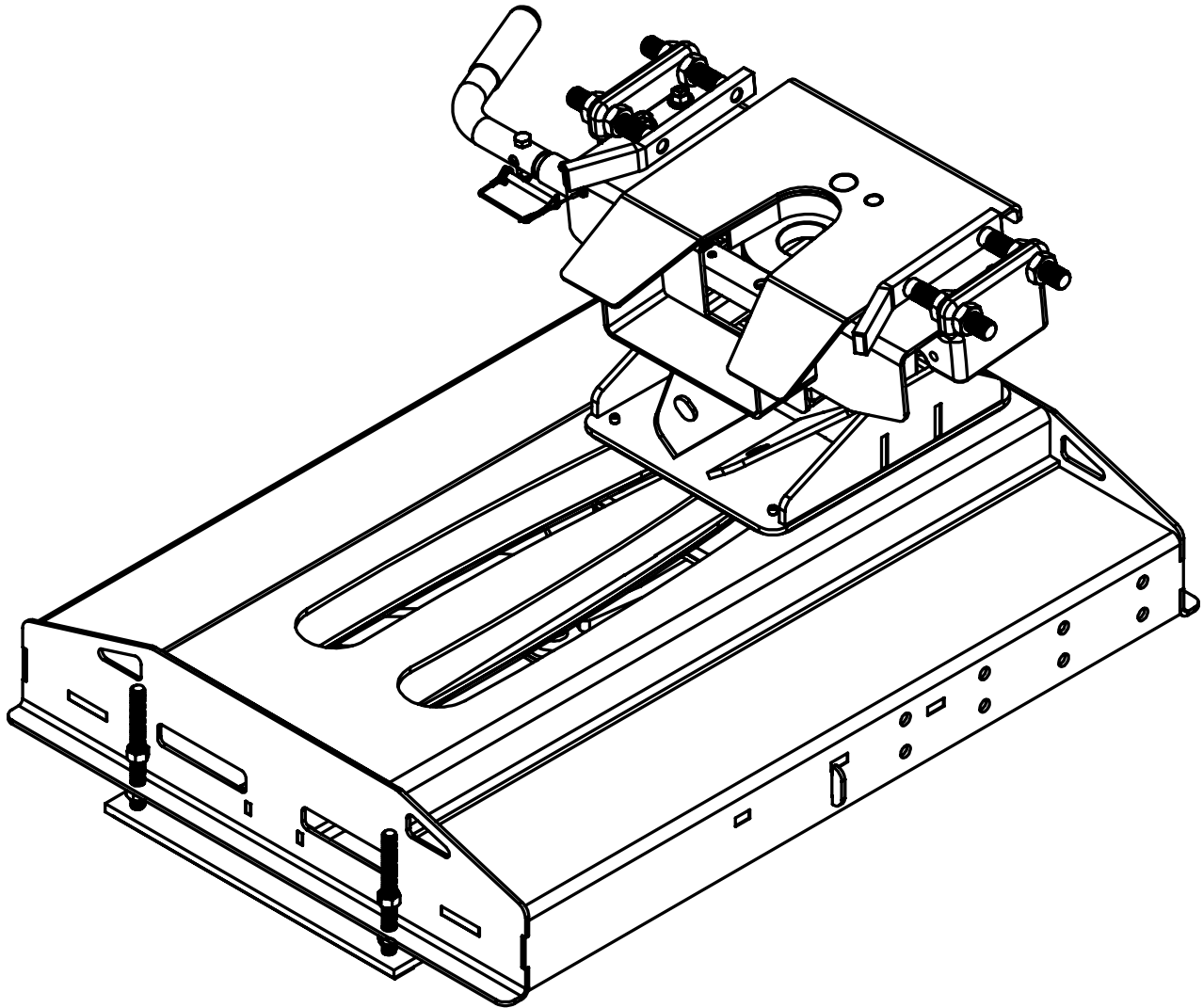

US Pat. 10,850,581

OPERATOR MANUAL

INTRODUCTION

WARRANTY POLICY, OPERATOR MANUALS, PARTS MANUALS & REGISTRATION

Go online to www.demco-products.com to review Demco warranty policies, operator manuals and register your Demco product.

Please consult vehicle owner's manual for 5th wheel towing instructions.

VERY IMPORTANT - PLEASE READ CAREFULLY

The 5th Wheel Autoslide hitch was designed for use with recreational style fifth wheel trailers with a 2" king pin only. It is not designed or intended for commercial, industrial, or agricultural type towing applications or similar type applications (i.e.- car trailer, flat bed, horse, etc.).

This hitch is designed for use with short box trucks that have a 5 1/2 foot box. There is no expressed or implied guarantee that a full turn can or will be achieved with the Autoslide hitch.

It is designed to work with standard trailer pin boxes between 12" minimum to 14" maximum width. Optional adapter plates are required for most suspension pin boxes.

Any use of the Autoslide hitch, other than its intended use, may void any manufacturer's warranty(s), expressed or otherwise.

The Autoslide automatic sliding hitch is designed for short box trucks to give additional clearance between the truck's cab and the trailer during turning maneuvers. This hitch may allow 90° turns, but NOT IN EVERY CASE.

There are many variables that can influence the ability to make a full 90° turn, such as trailer width, sharp or rounded trailer corners, truck cab profile. The placement of the trailer king pin box also has a part in determining the turning ability of the truck and trailer. It is always recommended, even with an automatic sliding hitch, that the trailer be equipped with an extended pin box that projects out forward from the trailer.

Caution should always be exercised when using this or any hitch to ensure that the driver is aware of clearance between the truck and trailer when executing turning maneuvers.

VERY IMPORTANT - PLEASE READ CAREFULLY

The Demco 5th Wheel Autoslide hitch comes assembled from the factory to help make the installation easier and quicker. The only prep work necessary is to bolt on the side plates. There are two different mounting systems for the Autoslide hitch. It can be mounted on either the Premier/UL base rails or the UMS (Underbed Mounting System) base rails. Once the mounting system has been determined there is a side rail kit available for either.

For the Premier/UL mounting system the 6003 adaptor side plate kit (shown below) will be used and for the UMS mounting system the 6004 adaptor side plate kit will be used. Instructions to install both types are included in the carton with the adaptor plates as well as with these instructions.

Also included with these instructions is a procedure for adjusting the king pin capture plates. This is the most critical procedure that needs to be done in order to ensure the proper and safe use of the hitch. Please read and follow the instructions on how to adjust them VERY CAREFULLY. These instructions also include the procedure for replacing the slide disc(s) if necessary (shown below). The Autoslide fifth wheel hitch comes with a limited five year warranty that covers most parts and labor. The slide disc is warranted for a period of one year as it is considered a consumable part.

CRITICALLY IMPORTANT

Capture plates must be adjusted to the width of the trailer pin box in order for the automatic slide mechanism to operate and function properly. Failure to do so can result in improper alignment and may cause damage to the hitch and/or trailer. It is best to measure the pin box width first and adjust the plates evenly on either side to 1/8" over the total width of the pin box. This adjustment is made only once at time of initial hookup, or if a trailer with a different width pin box is towed.

1. Measure the width of the pinbox.
2. Adjust the capture plates so they are 1/8" wider than the pinbox. Example: if pin box measures 12" the capture plates should measure 12-1/8". Use center pin to measure from so the capture plates are centered on the head. Final adjustment may be needed.
3. Finger tighten the two inside jam nuts against the capture plate mount.
4. Tightening outside jam nuts against thick mounting plate.

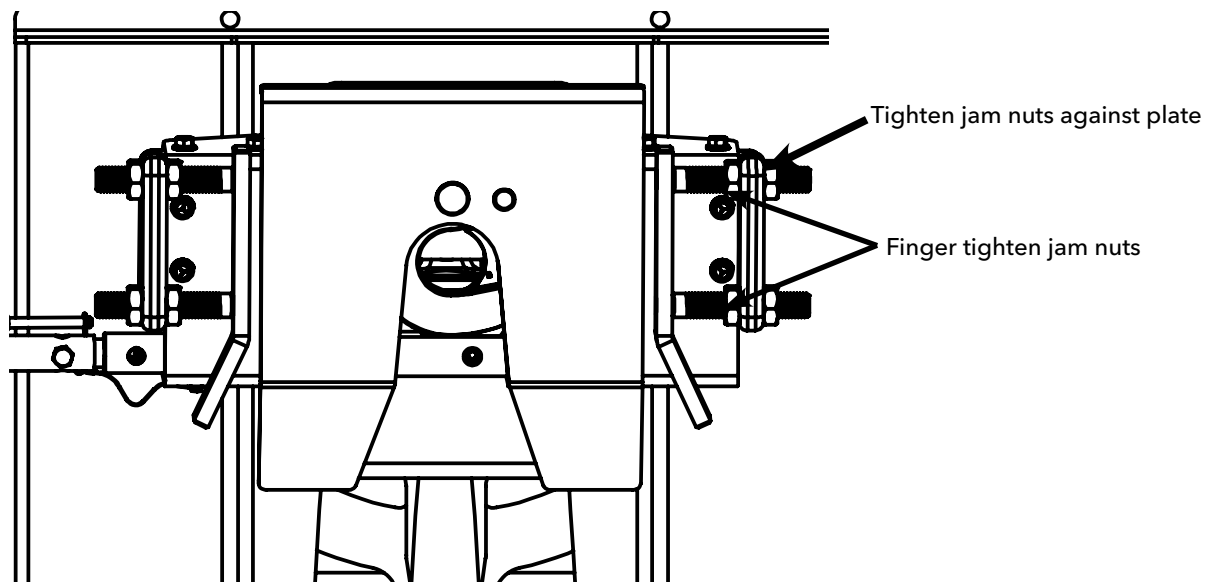

COUPLING PROCEDURE

Because the Autoslide hitch uses capture plates to maintain the hitch head position in relation to the trailer king pin, the trailer can only be coupled and uncoupled when it is in straight or slightly angled alignment. The Autoslide can couple and uncouple up to a 10-15° trailer angle quite easily. Anything over this degree of angle will not allow for proper coupling.

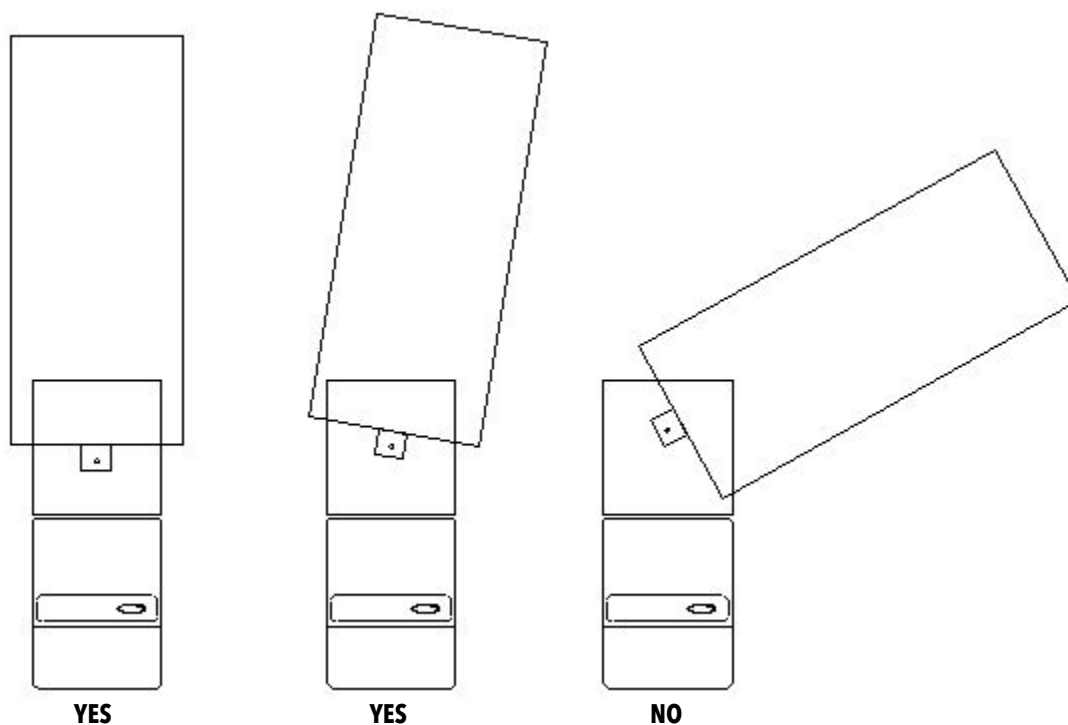

OPERATION

AUTOSLIDE INSPECTION AND CARE

The Autoslide hitch should be inspected before each trip to insure safe operation and travel.

Before each trip; check hitch for excessive movement or looseness in the slide assembly, some movement is normal. Check fasteners and pins for tightness and presence.

Once a month or every 5,000 miles, inspect the lower guide plates and roller for excessive wear that will effect the function of hitch, some wear is normal. Apply multi purpose or lithium grease to the side guide plates.

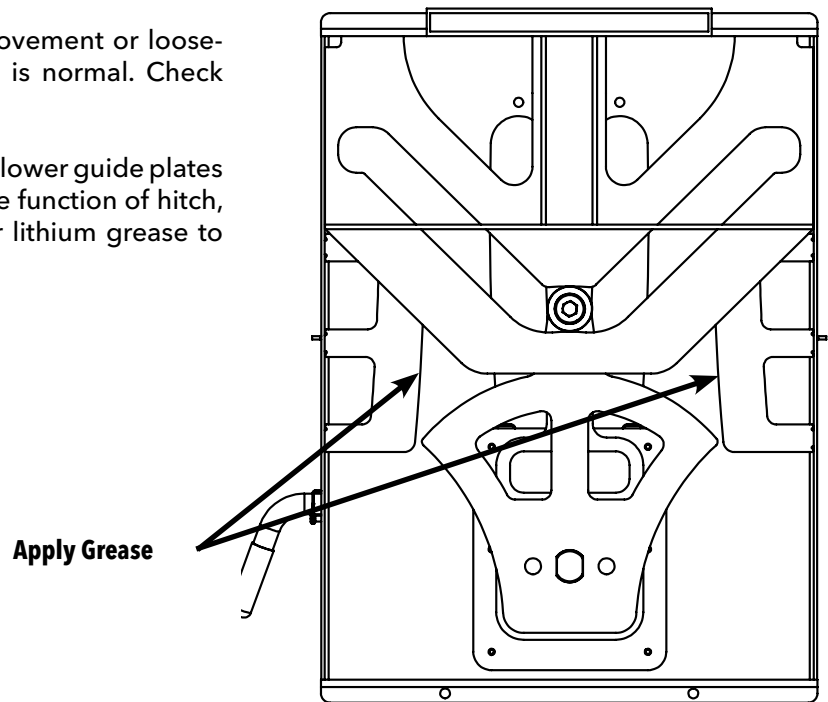

OUTRIGGER ADJUSTMENT

The Autoslide hitch has an outrigger or bar that is designed to help carry and distribute the hitch and trailer weight when the hitch is near its full travel distance. This outrigger needs to be adjusted after the hitch has been installed at its correct height within the truck bed. The outrigger bar and bolts need to be loosely fitted to the end plate of the hitch that is closest to the tailgate of the truck before the installation procedure. If the hitch is to be mounted in the lowest setting with the UMS mounting base rail system, install the outrigger as shown in the very bottom drawing (2), using only 1 nut on the top of the bent flange to secure the outrigger. On all other height settings, install the outrigger as shown in the top drawing (1), using 2 nuts to adjust and lock the bar.

Once the hitch is installed and locked into place in the truck bed, adjust the height of the outrigger bar so that it is snug up against the top of the truck bed and tighten both nuts to lock into place.

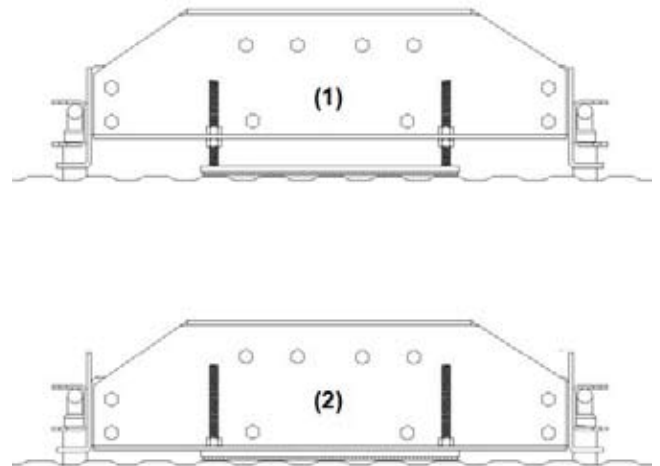

5TH WHEEL DOUBLE PIVOT HEAD ASSEMBLY

The dampener stops the hitch head from flopping back and forth in the truck when the trailer is not hooked up. The urethane compresses under load so it does not restrict the fore and aft movement when coupled.

Before attaching the hitch head to the saddle assembly the urethane dampener will need to be installed. It is included in the bag with the bolt and nut for the hitch handle. Simply press into hole that is punched into the bottom side of the hitch as shown below.

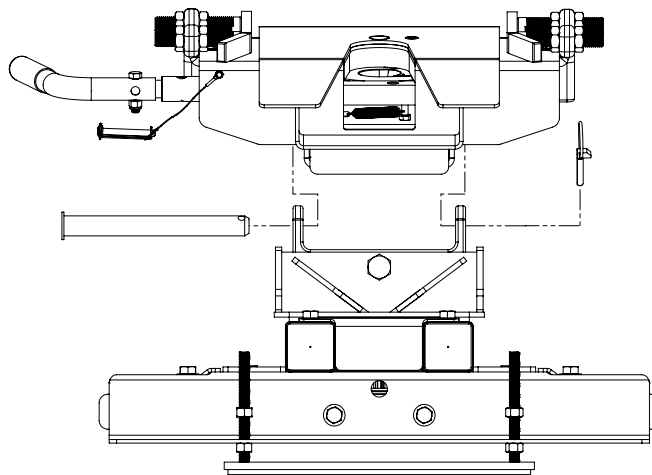
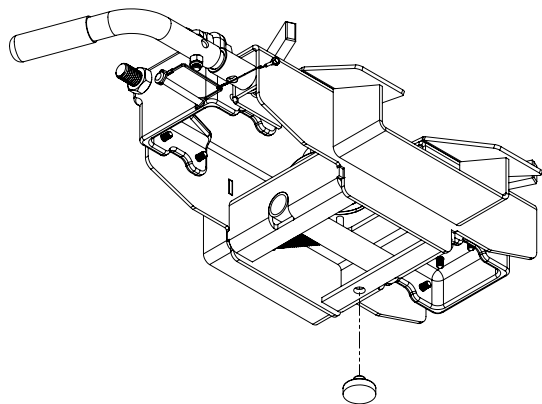

HANDLE ASSEMBLY INSTRUCTIONS

Note (Read carefully before installing): Handle can be positioned toward the front or the back if it is found to interfere with the trailer in any way. Verify this before traveling.

1. Slide yellow gripped handle over locking bar, the handle may point forward, upward or backward. ****DO NOT** have pointing upward if it is found to interfere with the trailer in any way during turning.
2. Fasten with 3/8" x 1 3/4" bolt and lock nut provided.

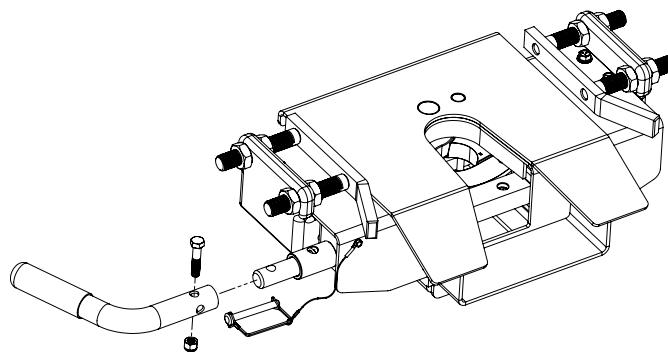

! WARNING

DO NOT install hitch handle in a position that the pin box could come in contact with or interfere with the latch of the hitch handle when turning! If the pin box contacts the hitch handle or its latch when turning, the trailer may become unhitched.

OPERATION

PROCEDURES TO CLOSE LOCKING BAR

Pull on handle with slight pressure while moving the secondary jaw to the right until the primary jaw is released. Slowly allow the handle to retract into the 5th wheel head. Caution: Do not put hands/fingers into the lock jaw area.

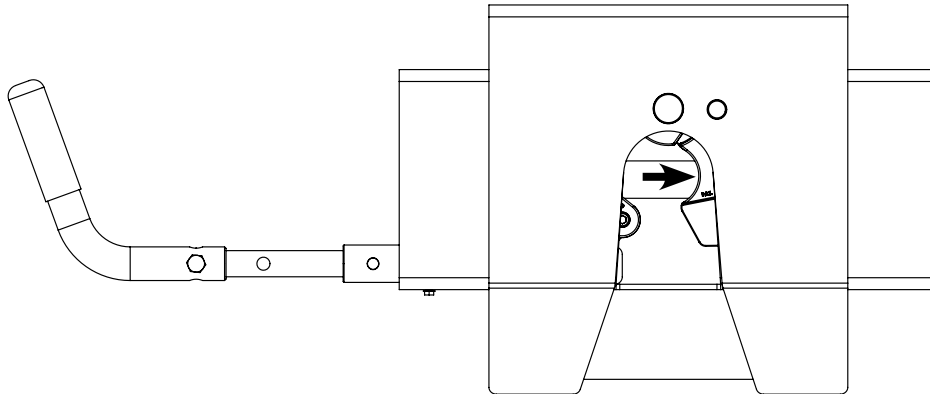

5TH WHEEL PIVOT HEAD MAINTENANCE

Your 5th wheel head has been tested and pre-greased at our production facility to help ensure easy operation of your new product.

As it is a new piece of equipment with some moving parts, a period of wearing in may be necessary to facilitate smoother operation for your new fifth wheel hitch. The most important thing to remember is to keep all moving parts well greased and lubricated. Your doing this will help to ensure longer product life.

Squirt WD40 or other oil into locking bar tube, open and close locking bar several times and wipe bar clean.

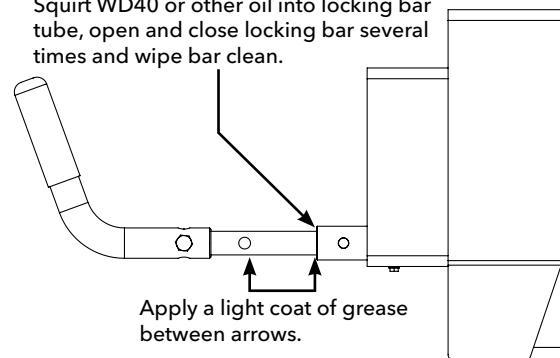

Apply a light coat of grease between arrows.

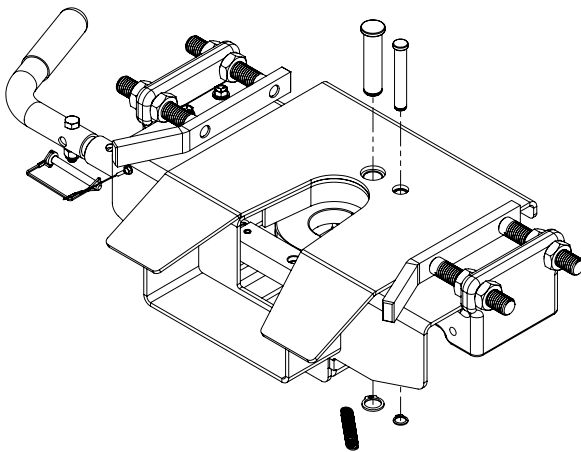

Jaw pins can be removed and greased by removing or unhooking jaw spring and both snap rings. Tap the pin up from bottom. Clean pins and inspect for wear, apply light coat of grease and reinstall pins, snap rings and spring.

5TH WHEEL HITCH OPERATION INSTRUCTIONS

COUPLING PROCEDURE

1. Place wheel chock on each side of trailer wheels.
2. Adjust trailer jacks until trailer is a height for hook up. King pin plate should contact hitch approximately 1/2" below level.

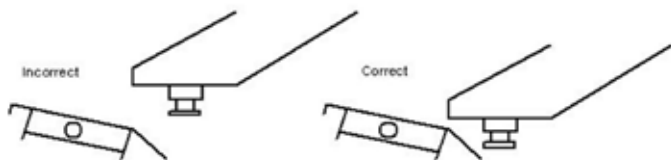

3. Lower tailgate of truck.
4. If hitch is in locked position, remove safety pin and pull handle out to the "Ready to Couple" position.
5. Line truck so that the hitch will accept king pin. Back truck up slowly towards trailer until king pin engages. Hitch will lock when king pin is fully engaged.
6. With the trailer coupled, visually check to see if hitch is completely locked by looking at the handle position, as well as visually checking to ensure that the jaw bar has traveled completely across the front of the king pin.
7. Place safety pin thru the tab and the hole in the handle. This will prevent handle from opening.
8. Connect power cable and breakaway switch cable between truck and trailer.
9. Close and latch tailgate.
10. Apply trailer brakes and try to pull forward slowly to double check that hitch is locked. Trailer should prevent truck from moving.
11. Completely raise trailer jacks. Check for proper clearance between truck box and trailer.
12. Pick up and store wheel chocks. You are now ready to travel.

UNCOUPLING PROCEDURE

1. Place wheel chocks on both sides of trailer wheels.
2. Lower trailer jacks to ground and extend until load is level with truck suspension. If on soft ground, place support under jack feet to prevent trailer from settling.
3. Lower tailgate on truck.
4. Disconnect power cable and break away switch.
5. Remove lock pin and pull handle out. If handle will not stay out, install safety pin in second handle hole just outside of frame handle bushing.
6. Drive truck slowly away from trailer.

VERY IMPORTANT MAINTENANCE INSTRUCTIONS

1. Inspect all fasteners for tightness at least every 2,000 miles of operation.
2. Inspect jaw and jaw bar for freedom of movement and proper operation before each use. Replace all damaged or worn parts.
3. Keep all moving parts of hitch well lubricated.
4. It is recommended to use grease or a 3/16" maximum Teflon disc to help prevent wear on top plate surface.

VERY IMPORTANT WARNINGS

1. Know your vehicle and trailer GVWR and CVWR. **DO NOT** exceed capacity of hitch.
2. Hitch is for use with only a standard 2" king pin.

Safety pin MUST be fastened securely before moving vehicle and/or traveling

Ready to Couple

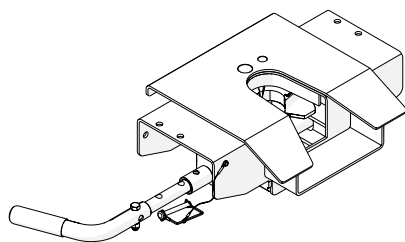

Remove safety lock pin if installed and pull handle until jaw locks open.

Coupled and Locked

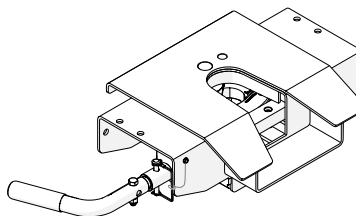

With handle in "Ready to Couple" position, back-up tow vehicle to couple trailer and hitch. Insert safety pin thru tab and hole in handle. **NOTE:** Ensure safety lock pin is inserted properly. Apply trailer brakes before jacks are raised and wheel chocks are removed.

Uncoupled

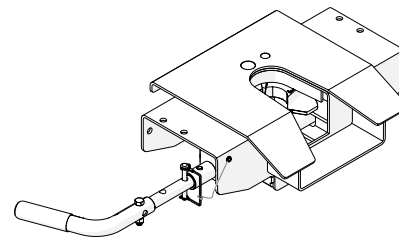

To uncouple, remove safety pin, pull handle straight out until the jaw locks open. If jaw will not stay open, install safety pin in second handle hole just outside of frame handle bushing.

VISUALLY INSPECT JAW LOCKING MECHANISM BEFORE TRAVELING

PARTS BREAKDOWN

6081 PIVOT HEAD PARTS BREAKDOWN

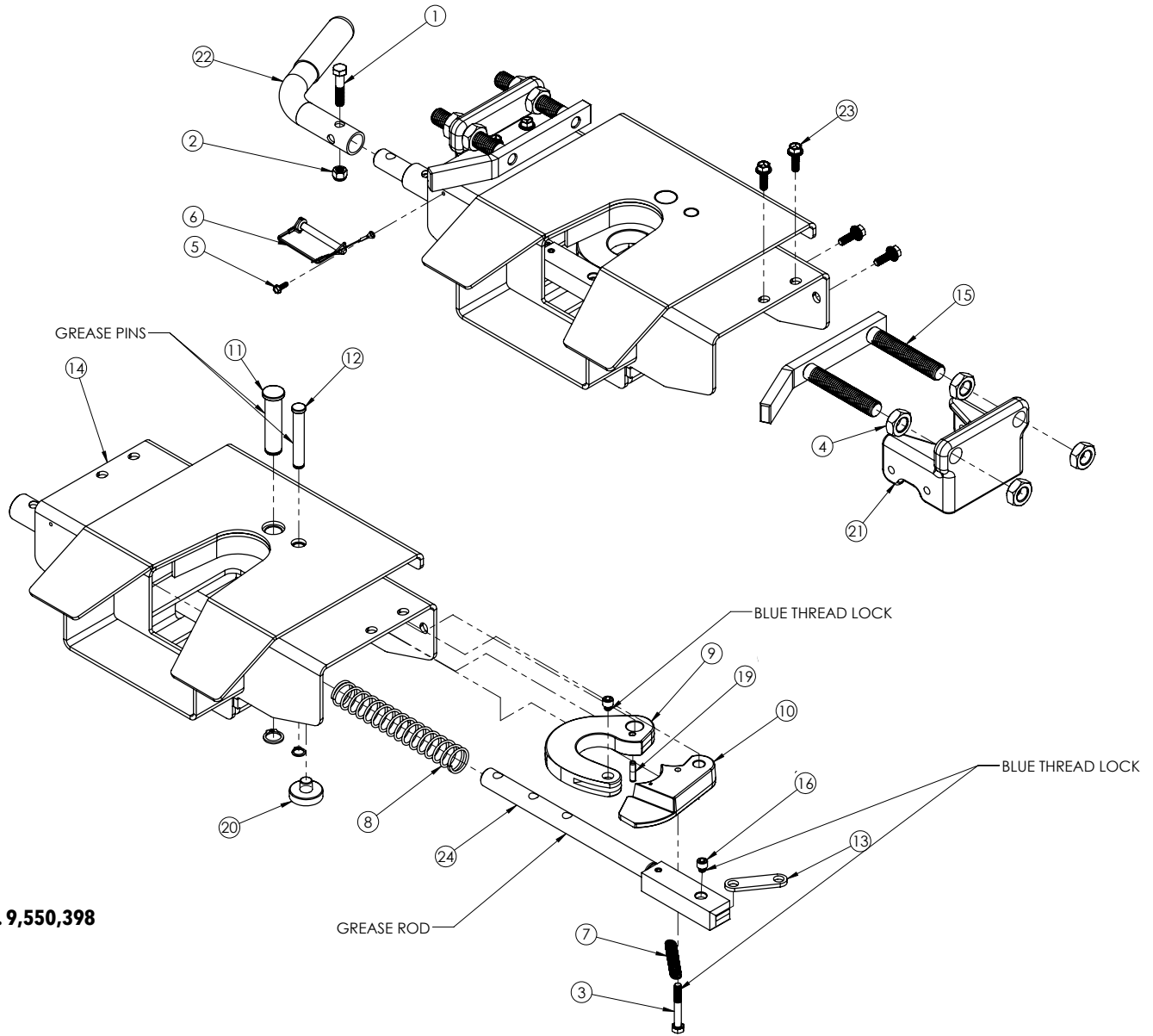

US Pat. 9,550,398

6081 Parts Breakdown

ITEM	PART #	DESCRIPTION	QTY
1	00908	BOLT, .375 NC X 1.75 HEX GR.5	1
2	02592	NUT, .375NC NYLON LOCK	1
3	03547	BOLT .313NC X 2.25 GR5 HEX	1
4	03701	NUT, .75 JAM	8
5	03787	SCREW #10NC X .50 SELF DRILLING	1
6	05337	SAFTY LOCK PIN ASSEMBLY	1
7	14315	SPRING, TENSION	1
8	14385	SPRING COMPRESS	1
9	14594-95	JAW HOOK	1
10	14595-95	SECONDARY LATCH JAW	1
11	14735-95	MAIN JAW PIN	1
12	14736-95	SECONDARY JAW PIN	1
Please order replacement parts by PART NO. and DESCRIPTION			

ITEM	PART #	DESCRIPTION	QTY
13	14737-95	BAR/JAW LINK	1
14	14741-76	5th WHEEL DOUBLE PIVOT HEAD	1
15	14743-95	CAPTURE PLATE ASSEMBLY	2
16	14747	SCREW .313NC X .25 SOCKET HD CAP	2
17	14749	SNAP RING EXT FOR .50 SHAFT	1
18	14750	SNAP RING EXT F/ .75SHAFT	1
19	14865	ROLL PIN, .25 X 1.00	1
20	15769	URETHANE PIVOT BUMPER 3/8" THICK	1
21	15894	CAPTURE PLATE MOUNT	2
22	15934	HJ HANDLE ASSEMBLY	1
23	16338	BOLT, .438NC X 1.00 SERR HEX GR5	8
24	6094	LOCKING BAR ASSEMBLY	1
Please order replacement parts by PART NO. and DESCRIPTION			

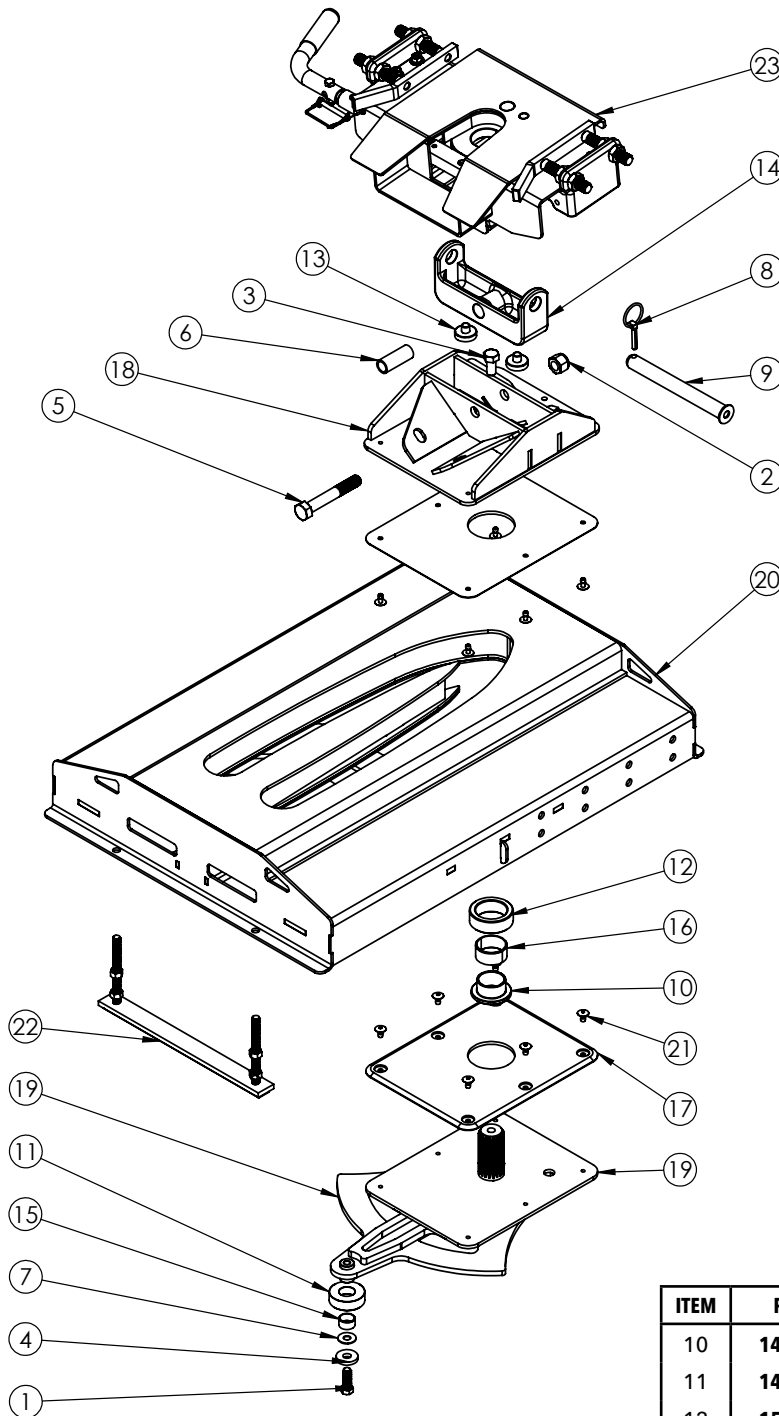

6330 Parts Breakdown

ITEM	PART #	DESCRIPTION	QTY
1	01254	BOLT, .50 NC X 1.50 GR.5 HEX	1
2	02961	.75NC NYLON INSERT LOCK NUT	1
3	05366	BOLT, .625 NC X 1.25 HEX HEAD GR.5	1
4	07908-95	HEAVY WASHER	1
5	11099	BOLT, .75 NC X 5.00 HEX HEAD GR. 8	1
6	11337-95	HINGE BUSHING	1
7	13317	CLEVIS SPACER WASHER	1
8	14221	LYNCH PIN, .313	1
9	14222-95	AS PIVOT PIN 1" X 9.38	1

Please order replacement parts by PART NO. and DESCRIPTION

ITEM	PART #	DESCRIPTION	QTY
10	14714-95	BEARING SPACER/SLEEVE	1
11	14985-95	ROLLER	1
12	15418-95	MAIN ROLLER	1
13	15769	URETHANE PIVOT BUMPER 3/8" THICK	2
14	15778-76	5th WHEEL HEAD YOKE	1
15	16235	BUSHING, 25MM	1
16	16689	BUSHING, 50MM	1
17	16841	AS WEAR PLATE	2
18	16842-76	AS UPPER SLIDE ASSEMBLY	1
19	16843-76	AS LOWER GUIDE ARM ASSEMBLY	1
20	16844-76	AUTOSLIDE 5.5' MAIN FRAME	1
21	16845	RIVET .25 x .625 LARGE DOME HD	12
22	6018	OUTRIGGER BAR ASSEMBLY	1
23	6081	5TH WHEEL DP HEAD F/AS	1

Please order replacement parts by PART NO. and DESCRIPTION

DEMCO

4010 320th St., Boyden, IA. 51234

Phone: (712) 725-2311

Fax: (712) 725-2380

Toll Free: 1-800-54DEMCO (1-800-543-3626)

**Demco warranty policies, operator manuals, and product registration
can be found online:**

www.demco-products.com

