

INSTALLATION MANUAL

70133

Level of Difficulty

Easy

Installation difficulty levels are based on time and effort involved and may vary depending on the installer level of expertise, condition of the vehicle and proper tools and equipment.

Installed Attachment Tabs

Height	19"
Width	33-1/2"

Parts List

Item	Qty	Description
1	1	Tow bar base plate, driver
2	1	Tow bar base plate, passenger
3	2	Tow bar mounting tab
4	2	Safety cable, 7,500 lbs.
5	4	Flat washer, 5/8"
6	4	Nylock nut, 5/8"-11, grade 5
7	2	Square hole spacer, 3/8" x 1.25 x 2.50"
8	2	Carriage bolt, 5/8"-11 x 1-3/4", grade 8
9	4	Hex head cap screw, 5/8"-11 x 6-1/2", grade 5
10	2	Fishwire, 5/8"
11	2	Serrated flange nut, 5/8"-11, grade 8
12	2	Caplugs, # dop-1375
13	2	Quick link, 1/2"

Tools Required

Socket, 8mm	Torque wrench
Socket, 18mm	Wrench, 7/16"
Socket, 7/16"	Wrench, 15/16"
Socket, 15/16"	Utility knife

⚠ WARNING

Never exceed the vehicle manufacturer's recommended towing capacity.

Product Photo



NOTICE

Visit www.curtmfg.com for a full-color copy of this instruction manual, as well as helpful videos, guides and much more!

Before you begin installation, read all instructions thoroughly.

Proper tools will improve the quality of installation and reduce the time required.

This installation requires:

- Remove factory tow loop bolts
- Fishwiring to install hardware

Periodic inspection of your product should be performed to ensure all hardware and / or components remain secure.

To help prevent damage to the product or vehicle, refer to the specified torque specifications when securing hardware during the installation process.

Product Registration and Warranty

CURT stands behind our products with industry-leading warranties. To get copies of the product warranties, register your purchase or provide feedback, visit: warranty.curtgroup.com/surveys

ASSEMBLY

Parts List

Item	Qty	Description
1	1	Tow bar base plate, driver
2	1	Tow bar base plate, passenger
3	2	Tow bar mounting tab
4	2	Safety cable, 7,500 lbs.
5	4	Flat washer, 5/8"
6	4	Nylock nut, 5/8"-11, grade 5
7	2	Square hole spacer, 3/8" x 1.25 x 2.50"
8	2	Carriage bolt, 5/8"-11 x 1-3/4", grade 8
9	4	Hex head cap screw, 5/8"-11 x 6-1/2", grade 5
10	2	Fishwire, 5/8"
11	2	Serrated flange nut, 5/8"-11, grade 8
12	2	Caplugs, # dop-1375
13	2	Quick link, 1/2"

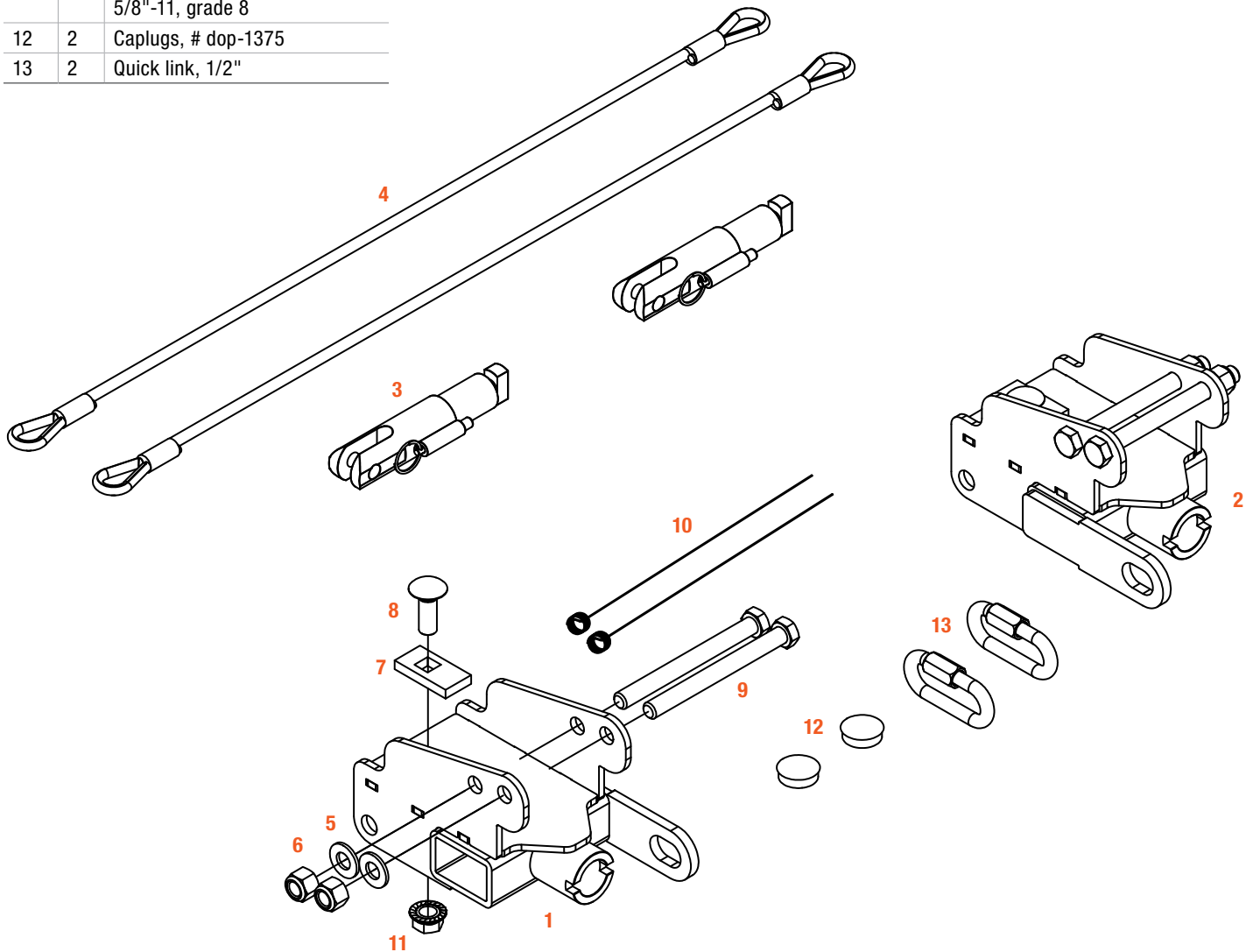

Step 1

Remove the thirteen bolts from the bumper air dam using an 8mm socket. Remove three bolts on each end from above and the rest from below.

Remove the air dam and set aside.



Step 2

Remove the four factory bolts and nuts from the fascia bracket using an 18mm socket. Do this on both sides of the vehicle. Remove brackets and return to vehicle owner.

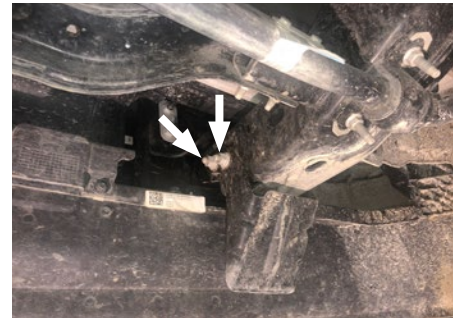
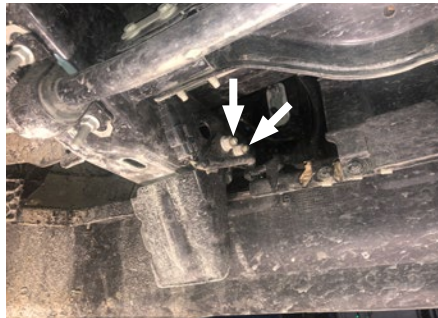

Step 3

Fishwire (#10) the 5/8" x 1-3/4" carriage bolt (#8) with square hole spacer (#7) into the bottom frame hole through the end of the frame.

Slide the baseplate (#1, #2) onto the bottom of the frame with safety cable loop towards the center of the vehicle. Line up the holes with the holes in the frame. Loosely install the 5/8" flange nut (#11), as shown, on both sides of the vehicle.

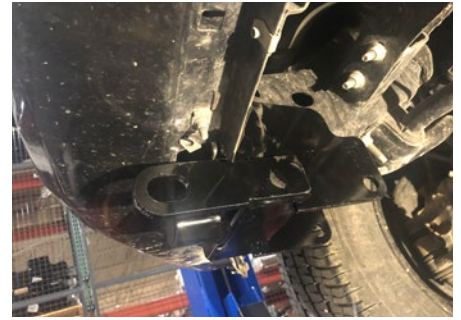

Step 4

Insert two 5/8" x 6-1/2" hex head cap screws into the holes on both side of the vehicle to secure the baseplate in place.



Step 5

Install the two 5/8" nylock nuts (#6) and flat washers (#5) on each side.

Torque the long bolts to 128 lb-ft and the short bolts to 180 lb-ft.



Step 6

Install the permanent safety cables (#4) and quick links (#13), looping them around the vehicle frame and linking them to the tow bar base plates (#1,#2). There must be one cable on each side of the vehicle.

Make sure the cables do not pinch or interfere with any hoses, wiring or other components.

See 'Installing the Permanent Base Plate Safety Cables' for additional information.

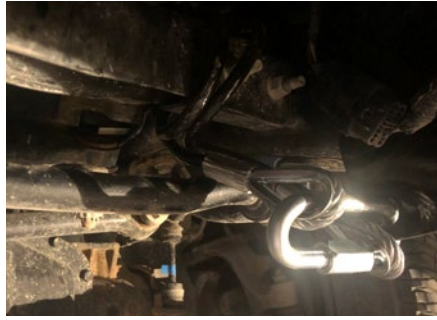

Step 7

Hold the bumper air dam as close to the original position as possible and mark and trim as necessary for baseplate clearance.



Step 8

Reinstall bumper air dam.

Final Installed Image



SAFETY CABLE INSTALLATION

Installing the Permanent Base Plate Safety Cables

When dinghy towing a vehicle with a tow bar, base plate safety cables should be used at all times. In the event of a disconnect, the safety cables are designed to help prevent complete vehicle separation. When installing the safety cables, use the illustrations below as a guide.

Installation guidelines

1. The cables must be connected to the base plate and the vehicle frame.
2. Two cables must be installed.
3. Each cable must meet or exceed the gross weight of the towed vehicle.
4. Make sure cables do not pinch or interfere with hoses, wiring or other components.

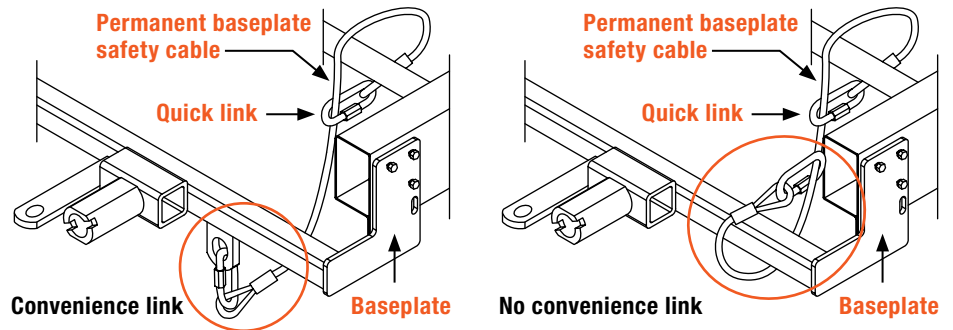

Note: Base plate safety cables are not a replacement for safety chains connecting the tow vehicle to the towed vehicle.

ADDITIONAL INFORMATION

Towing Tips

Check your equipment

Periodically check the condition of all towing equipment. Ensure all fasteners are tight and that all structural components are sound. Do not tow with worn or damaged parts.

Towing vehicle and trailer manufacturer's recommendations

Review the owner's manual for your towing vehicle and trailer for specific recommendations, capacities and requirements.