

**Air Lift1000™**  
by AIR LIFT®

**KIT 60763,  
60774, 60783,  
60797, 60798,  
60897**



*Cover  
illustration  
may not depict  
actual kit.*



## **INSTALLATION GUIDE**

For maximum effectiveness and safety, please read these instructions completely before proceeding with installation.

*Failure to read these instructions can result in an incorrect installation.*



# TABLE OF CONTENTS

<b>Introduction</b> .....	<b>2</b>
Important Safety Notice .....	2
<b>Installing the Air Lift 1000 System</b> .....	<b>3</b>
Hardware List .....	3
Tools List .....	3
Important Note .....	3
Section A Installation .....	3
Section B Installation .....	4
Section C Installation .....	5
Installing the Air Lines .....	5
Tee Air Line Routing .....	6
Dual Air Line Routing .....	7
Completing the Installation .....	8
<b>Maintenance and Operation</b> .....	<b>8</b>
Maintenance Guidelines .....	8
Operating Tips .....	8
<b>Warranty and Returns Policy</b> .....	<b>9</b>
<b>Replacement Information</b> .....	<b>10</b>
<b>Contact Information</b> .....	<b>10</b>
<b>Template</b> .....	<b>11</b>

# Introduction

The purpose of this publication is to assist with the installation, maintenance and troubleshooting of the Air Lift 1000 air spring kit.

It is important to read and understand the entire installation guide before beginning installation or performing any maintenance, service or repair. The information here includes a hardware list, tools list, step-by-step installation information, and maintenance tips.

Air Lift Company reserves the right to make changes and improvements to its products and publications at any time. Contact Air Lift Company at (800) 248-0892 or visit us online at [www.airliftcompany.com](http://www.airliftcompany.com) for the latest version of this manual.

## IMPORTANT SAFETY NOTICE

The installation of this kit does not alter the Gross Vehicle Weight Rating (GVWR) or payload of the vehicle. Check your vehicle's owner's manual and do not exceed the maximum load listed for your vehicle.

**Gross Vehicle Weight Rating:** The maximum allowable weight of the fully loaded vehicle (including passengers and cargo). This number — along with other weight limits, as well as tire, rim size and inflation pressure data — is shown on the vehicle's Safety Compliance Certification Label.

**Payload:** The combined, maximum allowable weight of cargo and passengers that the truck is designed to carry. Payload is GVWR minus the Base Curb Weight.

## NOTATION EXPLANATION

Hazard notations appear in various locations in this publication. Information which is highlighted by one of these notations must be observed to help minimize risk of personal injury or possible improper installation which may render the vehicle unsafe. Notes are used to help emphasize areas of procedural importance and provide helpful suggestions. The following definitions explain the use of these notations as they appear throughout this guide.

** DANGER**

INDICATES IMMEDIATE HAZARDS WHICH WILL RESULT IN SEVERE PERSONAL INJURY OR DEATH.

** WARNING**

INDICATES HAZARDS OR UNSAFE PRACTICES WHICH COULD RESULT IN SEVERE PERSONAL INJURY OR DEATH.

** CAUTION**

INDICATES HAZARDS OR UNSAFE PRACTICES WHICH COULD RESULT IN DAMAGE TO THE MACHINE OR MINOR PERSONAL INJURY.

**NOTE**

*Indicates a procedure, practice or hint which is important to highlight.*

**HARDWARE LIST**

Item	Part #	Description.....Qty
A	*	Air spring..... 2
B	09447	Protector ..... 2
C	20315	15' Hose..... 1
D	10638	Air line clamp ..... 6
E	10466	Zip tie ..... 2
F	21230	Valve cap ..... 2
G	21233	5/16" Hex nut ..... 4
H	21234	Rubber washer..... 2
I	18411	5/16" Star washer..... 2
J	18405	5/16" Flat washer ..... 2
K	21236	Barbed tee ..... 1
L	21455	Valve ..... 2

**TOOLS LIST**

Description.....Qty
Hoist or floor jacks ..... 2
Safety stands..... 1
Safety glasses ..... 1
Air compressor or compressed air source..... 1
Spray bottle with dish soap/water solution ..... 1

\*Air spring varies per specific kit number.



Missing or damaged parts? Call Air Lift customer service at (800) 248-0892 for a replacement part.

# Installing the Air Lift 1000 System

## IMPORTANT NOTE

This kit fits many different vehicles. Please consult the following listings for the appropriate installation section for your particular vehicle.

**Section A:** General Motors A (Century, Celebrity, Cutlass Cierra 6000) and X (Skylark, Citation, Omega, Phoenix) front wheel drive, with solid rear axle cars; Ford, Lincoln, Mercury full size and mid-size cars; Chevy Lumina APV, Olds Silhouette, and Pontiac Transport; Nissan Pathfinder; Isuzu Trooper, Amigo, and Vehicross

**Section B:** Camaro, Firebird, Monza, Skyhawk, Starefire, Astre, Sunbird, and Vega

**Section C:** General Motors E (Toronado, Riviera, El Dorado, SeVille) and H (LeSabre, Electra, Park Ave, DeVille, Eighty-Eight, Ninety-Eight, and Bonneville) Cars; Kia Sedona Van; Nissan Morano, Toyota Scion XB.

## SECTION A INSTALLATION

1. Some Ford, Lincoln, and Mercury models come equipped with a rubber sleeve inside of the rear coil springs. This needs to be removed prior to proceeding with the installation. It can either be cut out or pulled out with vise grips.
2. Jack up the rear of the vehicle or raise on a hoist. Support the frame with safety stands. Lower the axle or raise the body of the vehicle until the suspension is fully extended (fig. 1).
3. If necessary, additional clearance between the coil may be obtained by removing the shock absorbers from the lower mountings and lowering the suspension an additional two inches.



OBSERVE THE TENSION ON THE BRAKE LINE. DO NOT STRAIN.

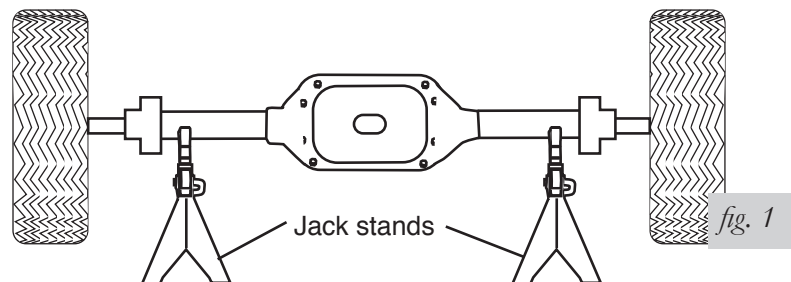

4. Remove the plastic cap from the barbed stem on the end of the air spring and exhaust all the air from the air spring by rolling it up towards the barbed stem. Replace the cap so that the air spring holds its flat shape. Form the air spring into a hot dog bun shape (fig. 2).

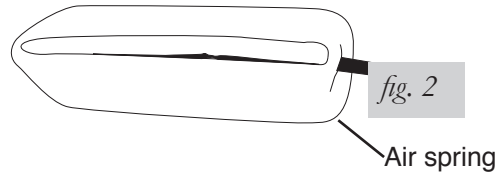

5. Insert the stem end of the air spring into the lowest opening of the coil (valve stem up). Push the air spring into the coil spring by hand or with a blunt object such as a spoon-type tire iron (fig. 3).
6. When the air spring is completely within the coil, remove the cap and allow the air spring to assume its original shape.
7. Push the air spring to the bottom of the coil and insert the protector on top of the air spring (fig. 4).
8. Continue with "Installing the Air Line."

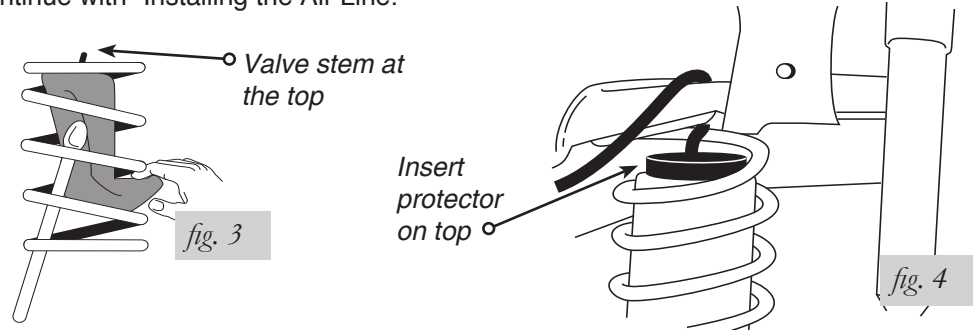

## SECTION B INSTALLATION

1. Jack up the rear of the vehicle or raise on a hoist. Support the frame with safety stands (see fig. 1).
2. Detach the shock absorber lower ends from the axle. Lower the axle or raise the body to permit the removal of the coil spring.
3. 1975 and up Vega, Monza, Starfire, Skyhawk, and Sunbird only:
  - a. Remove the upper bound bumper/cone assembly with coil spring (fig. 5). The bumper/cone assembly will not be reused, as the air spring replaces its function.
  - b. Cut out circle "C" on the template (see Template on page 11) and place onto the lower spring seat, holding it in position with a dab of grease. Center punch and drill a 1/2" hole in the marked location (fig. 6).

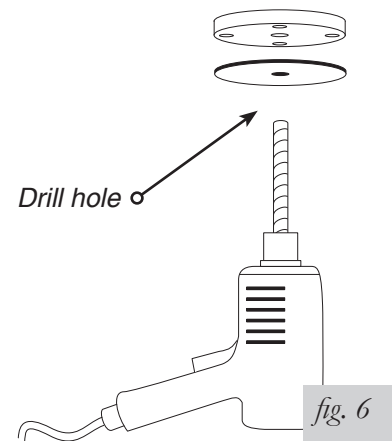
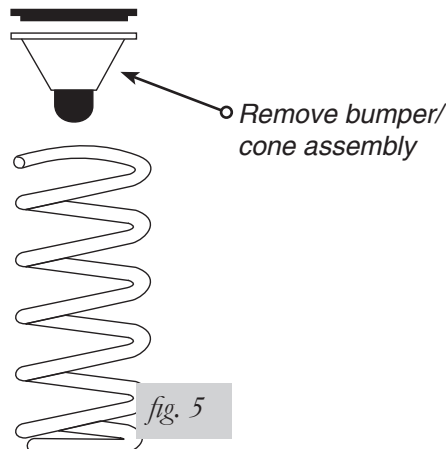

4. Insert the air spring into the coil with the stem down (fig. 7).
5. If removed, place the upper spring insulator on top of the coil spring. Index it so that the notch fits on the end of the spring.
6. Replace the coil springs and air spring assembly into the vehicle spring seats, insuring that the end of the spring is indexed properly into the notch in the seat.
7. Push the air spring to the top of the coil spring and insert the protector on top of the lower spring seat (fig. 8).
8. Continue with "Installing the Air Line."

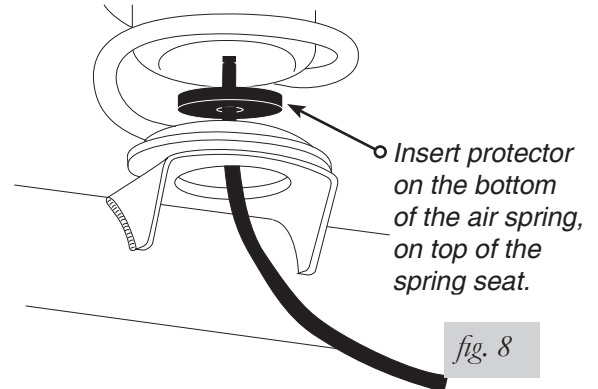
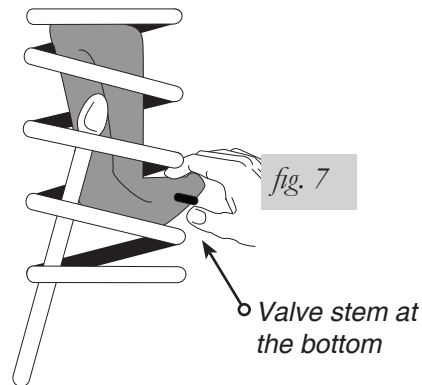

## SECTION C INSTALLATION

1. Jack up the rear of the vehicle or raise on a hoist. Support the frame with safety stands. Lower the axle or raise body of the vehicle until the suspension is fully extended (see fig. 1).
2. Some of the vehicles in this section do not have a hole in the lower spring. Cut out circle "D" on the template and place into the lower spring seat, holding it in place with a dab of grease. Center punch and drill a  $\frac{3}{4}$ " hole in the marked location.
3. Remove the plastic cap from the barbed stem on the end of the air spring and exhaust all the air from the air spring by rolling it up towards the barbed stem. Replace the cap so that the air spring holds its flat shape. Form the air spring into a hot dog bun shape.
4. Insert the air spring into the coil with the stem down. Push the air spring into the coil spring by hand or carefully with a blunt object such as a spoon-type tire iron (see fig. 7).
5. When the air spring is completely within the coil, remove the cap and allow it to assume its original shape.
6. Push the air spring to the top of the coil and insert the protector on the bottom of the air spring (see fig. 8).
7. Continue with "Installing the Air Line."

## INSTALLING THE AIR LINE

Tee air line installation is recommended unless weight in the vehicle varies from one side to the other and unequal pressures are needed to level the load. Dual air lines are used in this case.

## TEE AIR LINE ROUTING

### CAUTION

TO PREVENT THE AIR LINE FROM MELTING, MAINTAIN AT LEAST 8" FROM THE EXHAUST SYSTEM TO THE AIR LINE.

1. Locate the desired tee location on the frame rail or cross member. Determine and cut adequate length of air line to reach from tee to the left and right side air springs.

### CAUTION

LEAVE SUFFICIENT AIR LINE SLACK TO PREVENT ANY STRAIN ON THE FITTING DURING AXLE MOTIONS.

2. Slide an air line clamp onto the air line.
3. Push the air line over one side of the tee until all the barbs are covered. With a pair of pliers, slide the air line clamp forward until it fully covers the barbed section. Repeat entire procedure for other leg of the tee (fig. 9).
4. Route the air line along the cross member and either the lower control arm or the upper spring seat to the air spring.
5. Insert the air line through the spring seat and protectors.

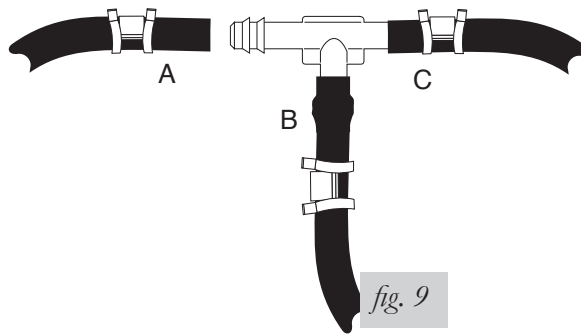

#### Use this procedure for all air line connections:

- a. Slide the air line clamp onto the air line.
- b. Push the air line over the barbed stem.
- c. Compress the ears on the air line clamp with pliers and slide it forward to fully cover the barbed section.

6. Push the air line onto the stem, covering all the barbs (fig. 10). With the pliers, slide the air line clamp upward until it fully covers the barbed section.
7. Push the remaining air line over the last fitting on the tee and route it along the frame to the desired inflation valve location. Attach the air line with plastic straps or wire.
8. Select a location for the inflation valve in the gas cap well, the trunk, rear bumper, fender flange or behind license plate, insuring that the valve will be protected and accessible with an air hose (fig. 11).

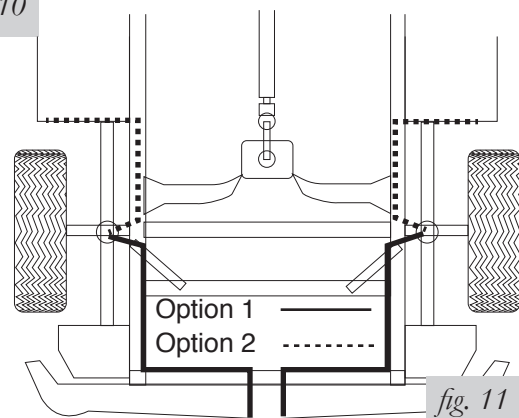
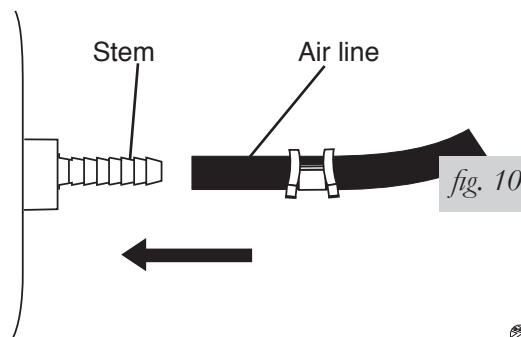



9. Drill a 5/16" hole for the inflation valve and mount as shown (fig. 12). The rubber washer serves as an outside weather seal.
10. Slide the air line clamp over the air line. Push the air line onto the fitting covering all barbs. Using pliers, slide the air line clamp forward until it fully covers the barbed section (fig. 13).

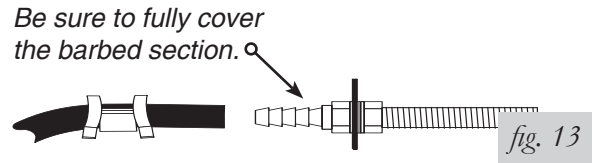
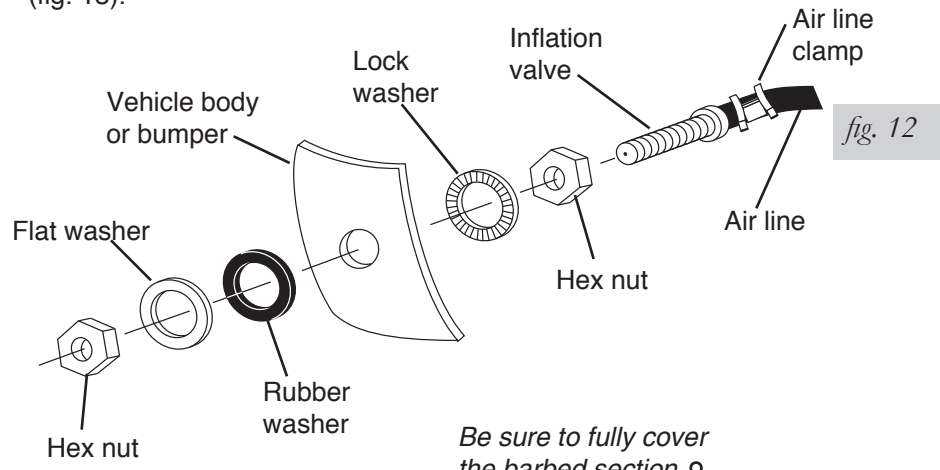

11. Raise the axle or lower the vehicle body until the air springs lightly touch the upper spring seat and lower spacers.
12. Check tail pipe clearance and insure that it is at least 2-3 inches from air spring. If necessary, loosen clamps and rotate or move to obtain additional clearance. If heat shield is provided, install. Attach shock absorbers if removed earlier in the installation.

**CAUTION**

DO NOT INFLATE AIR SPRINGS BEFORE READING THE MAINTENANCE AND OPERATION SECTION.

13. Continue to "Completing the Installation."

**DUAL AIR LINE ROUTING**

**CAUTION**

TO PREVENT AIR LINE FROM MELTING, KEEP IT AT LEAST 8" FROM EXHAUST SYSTEM.

1. Select a location for the inflation valves in the rocker panel flange, or rear bumper, assuring that each valve will be protected and accessible with an air hose.
2. Determine and cut adequate length of air line to reach from valve location to left side air spring.

**CAUTION**

LEAVE SUFFICIENT AIR LINE SLACK TO PREVENT ANY STRAIN ON FITTING DURING AXLE MOTIONS.

3. Insert the air line through the spring seat and protectors.
4. Slide air clamp onto the cut air line.
5. Push the air line onto the stem, covering all the barbed section (see fig. 10). With pliers slide the air line clamp forward until it fully covers barbed section.
6. Repeat process for right side.
7. Drill 5/16 " hole for inflating valves and mount as illustrated. Rubber washer is for outside weather seal (see fig. 12).
8. Route air line along control arm and frame to inflation valve location and cut off excess.

9. Slide a clamp onto the air line and push the air line over the fitting, covering all the barbs. With pliers slide the air line clamp forward until it fully covers the barbed section (see fig. 13).
10. Raise axle or lower body until air springs lightly touch the upper/lower spring seat and protectors.
11. Check tail pipe clearance and insure that it is at least 2-3 inches from air springs. If necessary, loosen clamps and rotate or move to obtain additional clearance. If heat shields are supplied, install them. Attach shock absorbers if removed earlier in the installation.

**CAUTION**

DO NOT INFLATE AIR SPRINGS BEFORE READING THE MAINTENANCE AND OPERATION SECTION.

### COMPLETING THE INSTALLATION

1. Inflate the air springs to 35 p.s.i. Test for air leaks by applying a liquid solution of 1/5 dish soap to 4/5 water to all valve cores, fittings and connections.
2. Lower vehicle to the ground. Read Maintenance/Operation Tips for proper care of your air springs.
3. Recheck air pressure after 24 hours. A 2-4 p.s.i. loss after initial installation is normal. If pressure has dropped more than 5 lbs retest for leaks.

## Maintenance and Servicing

Minimum Air Pressure	Maximum Air Pressure
<b>5 p.s.i.</b>	<b>35 p.s.i.</b>
FAILURE TO MAINTAIN CORRECT MINIMUM PRESSURE (OR PRESSURE PROPORTIONAL TO LOAD), BOTTOMING OUT, OVER-EXTENSION OR RUBBING AGAINST ANOTHER COMPONENT WILL VOID THE WARRANTY.	

### MAINTENANCE GUIDELINES

By following these steps, vehicle owners will obtain the longest life and best results from their air springs.

1. Check the air pressure weekly.
2. Always maintain at least the recommended minimum air pressure to prevent the air spring from being pinched. Never inflate beyond the maximum air pressure.
4. If you develop an air leak in the system, use a soapy water solution of 1/5 liquid dish soap and 4/5 water to check all air line connections and the inflation valve core before deflating and removing the air spring.
5. Always add air to springs in small quantities, checking the pressure frequently. Sleeves require less air volume than a tire and inflate quickly.

### OPERATING TIPS

1. Inflate your air springs to 35 p.s.i. before adding the payload. This will allow the air spring to properly mesh with the coil spring. After the vehicle is loaded, adjust your air pressure down to level the vehicle and for ride comfort.
2. When carrying a payload it will be helpful to increase the tire inflation pressure in proportion to any overload condition. We recommend a 2 p.s.i. increase above normal for each 100 lbs additional load on the axle.

**CAUTION**

DO NOT EXCEED THE VEHICLE MANUFACTURERS' MAXIMUM GROSS VEHICLE WEIGHT RATING.



# Warranty and Returns Policy

Air Lift Company warrants its products, for the time periods listed below, to the original retail purchaser against manufacturing defects when used on catalog-listed applications on cars, vans, light trucks and motorhomes under normal operating conditions for as long as Air Lift manufactures the product. The warranty does not apply to products that have been improperly applied, improperly installed, used in racing or off-road applications, used for commercial purposes, or which have not been maintained in accordance with installation instructions furnished with all products. The consumer will be responsible for removing (labor charges) the defective product from the vehicle and returning it, transportation costs prepaid, to the dealer from which it was purchased or to Air Lift Company for verification.

Air Lift will repair or replace, at its option, defective products or components. A minimum \$10.00 shipping and handling charge will apply to all warranty claims. Before returning any defective product, you must call Air Lift at (800) 248-0892 in the U.S. and Canada (elsewhere, (517) 322-2144) for a Returned Materials Authorization (RMA) number. Returns to Air Lift can be sent to: Air Lift Company • 2727 Snow Road • Lansing, MI • 48917.

Product failures resulting from abnormal use or misuse are excluded from this warranty. The loss of use of the product, loss of time, inconvenience, commercial loss or consequential damages is not covered. The consumer is responsible for installation/reinstallation (labor charges) of the product. Air Lift Company reserves the right to change the design of any product without assuming any obligation to modify any product previously manufactured.

This warranty gives you specific legal rights and you may also have other rights that vary from state-to-state. Some states do not allow limitations on how long an implied warranty lasts or allow the exclusion or limitation of incidental or consequential damages. The above limitation or exclusion may not apply to you. There are no warranties, expressed or implied including any implied warranties of merchantability and fitness, which extend beyond this warranty period. There are no warranties that extend beyond the description on the face hereof. Seller disclaims the implied warranty of merchantability. (Dated proof of purchase required.)

<b>Air Lift 1000</b> .....	<b>Lifetime Limited</b>	<b>LoadController/Dual</b> .....	<b>2 Year Limited</b>
<b>RideControl</b> .....	<b>Lifetime Limited</b>	<b>Load Controller (I)</b> .....	<b>2 Year Limited</b>
<b>LoadLifter 5000*</b> .....	<b>Lifetime Limited</b>	<b>Load Controller (II)</b> .....	<b>2 Year Limited</b>
<b>SlamAir</b> .....	<b>Lifetime Limited</b>	<b>SmartAir</b> .....	<b>2 Year Limited</b>
<b>AirCell</b> .....	<b>Lifetime Limited</b>	<b>Wireless AIR</b> .....	<b>2 Year Limited</b>
<b>Air Lift Performance**</b> .....	<b>1 Year Limited</b>	<b>WirelessONE</b> .....	<b>2 Year Limited</b>
<b>LoadController/Single</b> .....	<b>2 Year Limited</b>	<b>Other Accessories</b> .....	<b>2 Year Limited</b>

*\*formerly SuperDuty  
\*\*formerly LifeSTYLE & Performance and EasyStreet*

## Replacement Information

If you need replacement parts, contact the local dealer or call Air Lift customer service at (800) 248-0892. Most parts are immediately available and can be shipped the same day.

**Contact Air Lift Company customer service at (800) 248-0892, first if:**

- Parts are missing from the kit.
- Need technical assistance on installation or operation.
- Broken or defective parts in the kit.
- Wrong parts in the kit.
- Have a warranty claim or question.

**Contact the retailer where the kit was purchased:**

- If it is necessary to return or exchange the kit for any reason.
- If there is a problem with shipping if shipped from the retailer.
- If there is a problem with the price.

## Contact Information

If you have any questions, comments or need technical assistance, contact our customer service department by calling (800) 248-0892, Monday through Friday, 8 a.m. to 8 p.m. Eastern Time. For calls from outside the USA or Canada, our local number is (517) 322-2144.

For inquiries by mail, our address is PO Box 80167, Lansing, MI 48908-0167. Our shipping address for returns is 2727 Snow Road, Lansing, MI 48917.

You may also contact us anytime by e-mail at [sales@airliftcompany.com](mailto:sales@airliftcompany.com) or on the web at [www.airliftcompany.com](http://www.airliftcompany.com).

# Template

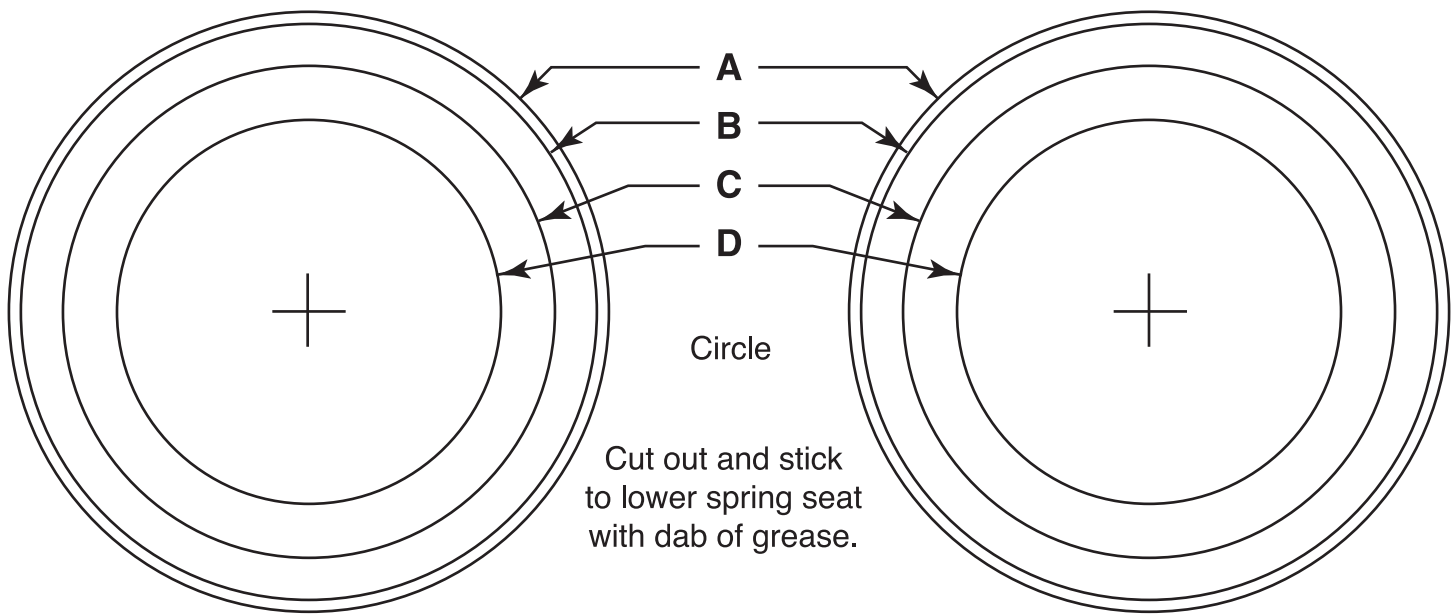



---

# Notes

## Need Help?

Contact our customer service department by calling (800) 248-0892, Monday through Friday, 8 a.m. to 8 p.m. Eastern Time. For calls from outside the USA or Canada, our local number is (517) 322-2144.

**Register your warranty online at  
[www.airliftcompany.com/warranty](http://www.airliftcompany.com/warranty)**



*Thank you for purchasing Air Lift products — the professional installer's choice!*

Air Lift Company • 2727 Snow Road • Lansing, MI 48917 or PO Box 80167 • Lansing, MI 48908-0167  
Toll Free (800) 248-0892 • Local (517) 322-2144 • Fax (517) 322-0240 • [www.airliftcompany.com](http://www.airliftcompany.com)

Printed in  
the USA