

AIRLIFT 1000

BY



MN-408
(04809)
ECR6529

KIT #60743

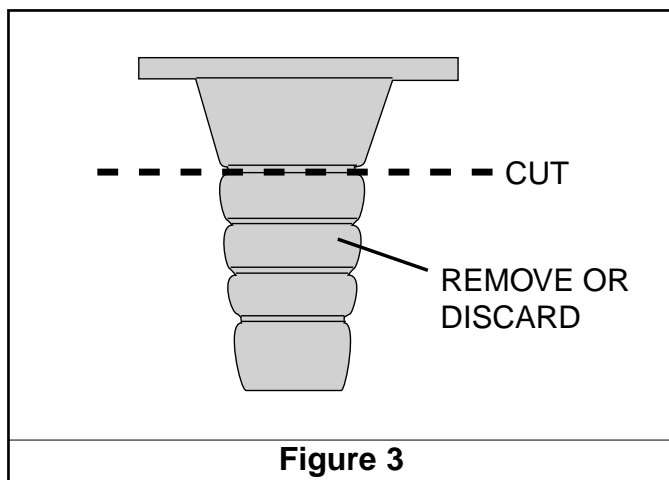
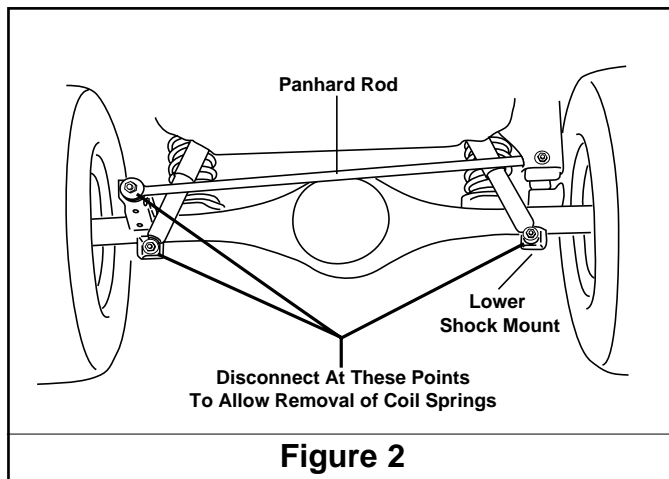
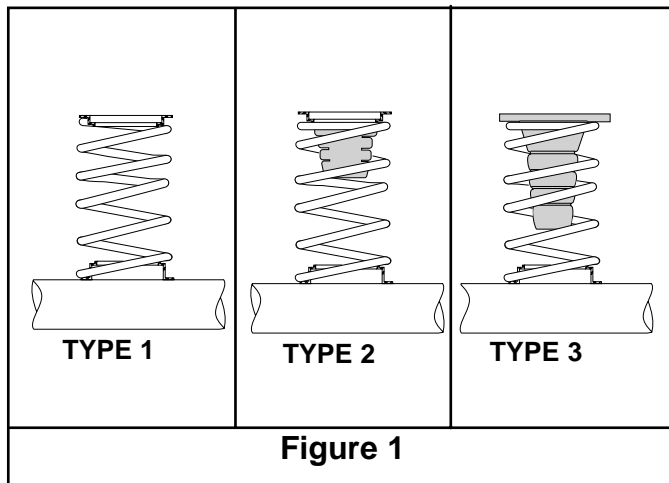

1. Jack up rear of vehicle or raise on hoist. Support frame with safety stands.
2. The coil springs must be removed for installation:
 - a. Detach the shock absorbers at the lower shock mount (Figure 2).
 - b. Detach the panhard rod at the lower axle mount (Figure 2).
 - c. If there is a rear anti-sway bar, you may have to disconnect the links.
 - d. Mark the position of the coil spring on the upper spring seat so that the spring can be reinstalled in the same position.
 - e. Carefully lower the axle until the coil springs are free. **CAUTION: Do not strain brake lines.** Disconnect brake line brackets if necessary. Remove coil springs.
3. There are three different combinations of jounce bumpers for this vehicle. Installation depends on what style the vehicle has.

Type 1: If there is no jounce bumper at top spring seat (see Figure 1), and there is a large hole, insert the protector and cylinder so stem is up. See Figure 4.

Type 2: If there is a small jounce bumper (approximately 3" long) at the top of the coil spring, unbolt and discard (see Figure 1). Drill a 9/16" hole in lower spring seat using center template circles. Insert cylinder and protector in coil spring with stem down. See Figure 4.

Type 3: If there is a large jounce bumper at the top of the coil spring (Figure 1) it will be necessary to trim the jounce bumper as specified in Figure 3. Center template, mark and drill a 9/16" hole in lower spring seat for hose access to cylinder. Insert cylinder stem down. See Figure 4.
4. Select either Dual Air Line or Tee Air line option depending on use of vehicle. The tee airline installation is best for vehicles that are loaded evenly from side to side. The dual air line installation should only be used if vehicle will have an unbalanced side to side loading; i.e. considerably more load on left side than right, or vice versa. Depending on your chosen installation, proceed with I (tee) or II (dual).

I. TEE AIR LINE ROUTING

TO PREVENT AIR LINE FROM MELTING, KEEP IT AT LEAST EIGHT INCHES FROM EXHAUST SYSTEM.

- A. Locate desired tee location on the frame rail or cross member.
- B. Determine and cut adequate length of air line to reach from tee to left and right side on air cylinders.

CAUTION: LEAVE SUFFICIENT AIR LINE SLACK TO PREVENT ANY STRAIN ON FITTING DURING AXLE MOTIONS.

- C. Slide air line clamp onto the air line.
- D. Push the air line over one side of the tee until all the barbs are covered. With pliers slide the air line clamp forward until it fully covers the barbed section. Repeat procedure for other leg of tee (Figure 8).
- E. Route air line along cross member and upper spring seat to air cylinder (Figure 5).
- F. Insert air line through spring seat and protector (Figure 4).
- G. Slide air line clamp onto the air line. Push the air line onto the stem, covering all the barbs (Figure 7). With pliers slide the air line clamp upward until it fully covers the barbed section. Repeat for the other side.
- H. Push the remaining air line over the last fitting on tee and route along frame to desired inflation valve location (Figure 5). Attach with plastic straps.
- I. Select a location for inflation valve in the gas cap well, the trunk, rear bumper, fender flange or behind the license plate, insuring that the valve will be protected and accessible with an air hose.
- J. Drill a 5/16" hole for inflation valve and mount as in illustration (Figure 9). Rubber washer is for outside weather seal.
- K. Slide air line clamp over the air line. Push air line onto fitting covering all barbs, with pliers slide the air line clamp forward until it fully covers the barbed section (Figure 10).
- L. Continue with step 6, page 3.

DO NOT INFLATE AIR CYLINDERS BEFORE READING MAINTENANCE & OPERATING TIPS.

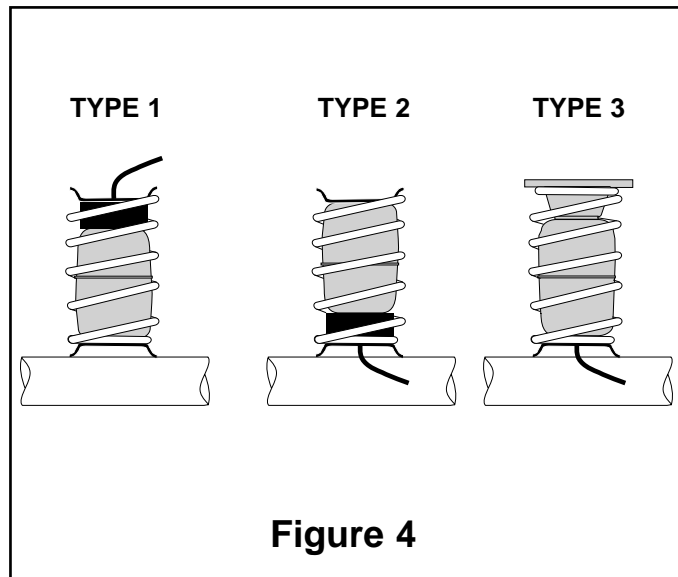

Figure 4

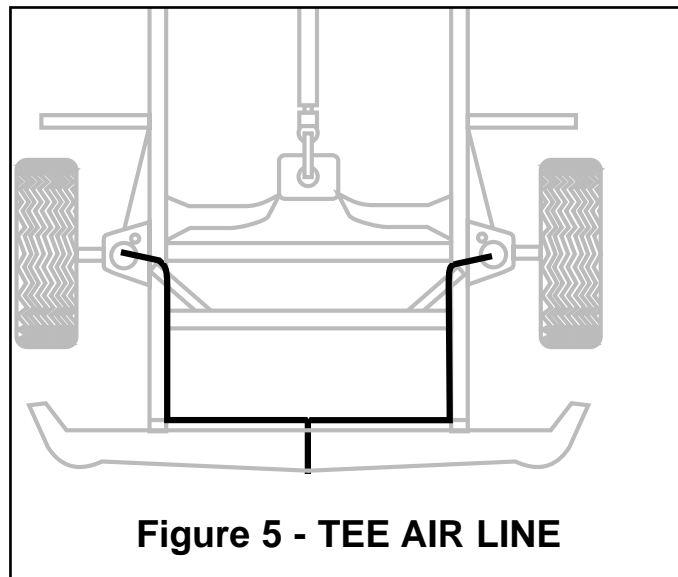

Figure 5 - TEE AIR LINE

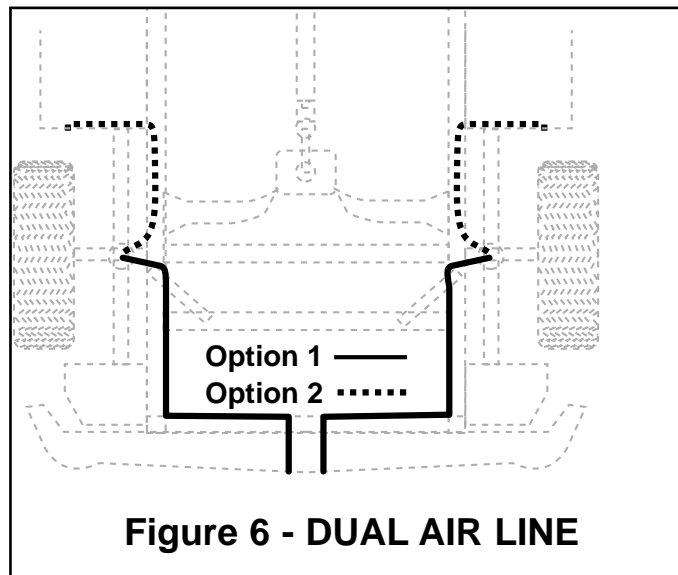

Figure 6 - DUAL AIR LINE

II. DUAL AIR LINE ROUTING

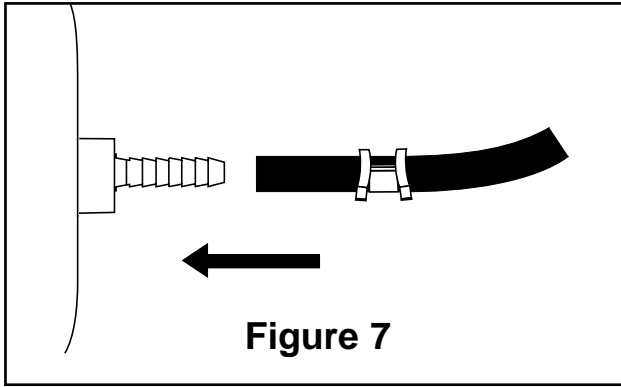
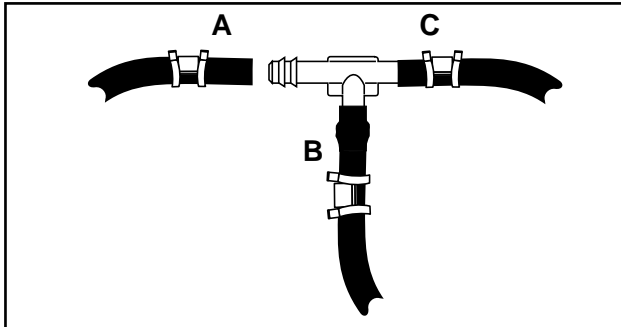

Figure 7



Use this procedure for all air line connections:
A. Slide air line clamp onto the air line
B. Push the air line over the barbed stem.
C. Compress the ears on the air line clamp with pliers and slide it forward to fully cover the barbed section.

Figure 8

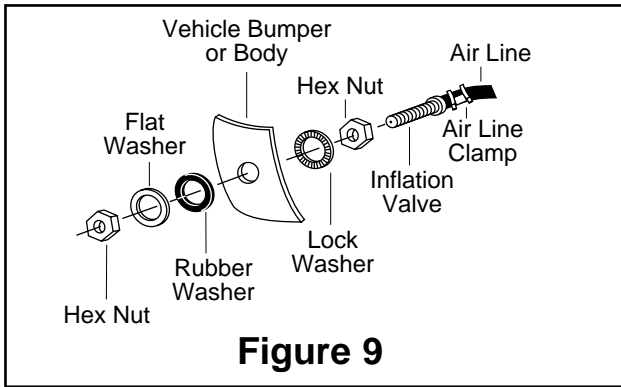

Figure 9

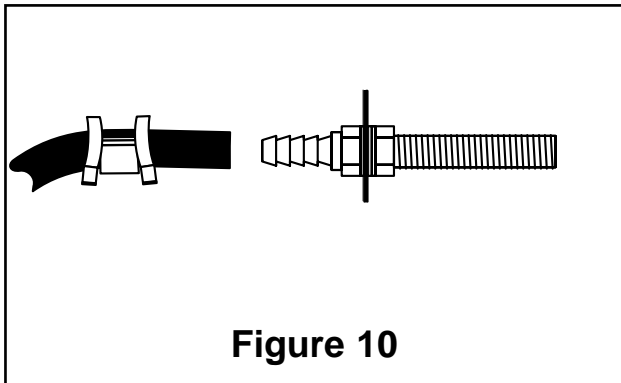

Figure 10

TO PREVENT AIR LINE FROM MELTING, KEEP IT AT LEAST EIGHT INCHES FROM EXHAUST SYSTEM.

- A. Select a location for the inflation valves in the rocker panel flange, or rear bumper, assuring that each valve will be protected and accessible with an air hose (Figure 6).
- B. Determine and cut adequate length of air line to reach from valve location to left side air cylinder.

CAUTION: LEAVE SUFFICIENT AIR LINE SLACK TO PREVENT ANY STRAIN ON VALVE STEM DURING NORMAL AXLE MOTIONS.

- C. Insert the air line through the spring seat and protector (Figure 4).
- D. Slide air line clamp onto the cut air line.
- E. Push the air line onto the stem, covering all the barbed section (Figure 7). With pliers slide the air line clamp forward until it fully covers barbed section.
- F. Repeat process for right side.
- G. Drill 5/16" hole for inflating valves and mount as illustrated. Rubber washer is for outside weather seal (Figure 9).
- H. Route air line along control arm and frame to inflation valve location and cut off excess.
- I. Slide a clamp onto the air line and push the air line over the fitting, covering all the barbs. With pliers slide the air line clamp forward until it fully covers the barbed section (Figure 10).

J. Continue with step 6.

DO NOT INFLATE AIR CYLINDERS BEFORE READING MAINTENANCE & OPERATING TIPS.

- 6. Reattach all components disconnected in step 2:
 - a. Reconnect brake lines to mounting brackets on rear axle and swaybar link if removed.
 - b. Reconnect panhard rod.
 - c. Reconnect shock absorbers.
 - d. Raise axle completely making sure air line going into cylinder does not get pinched.
- 7. Inflate Air Springs to 35 psi. Check for air leaks at all fittings and valve core with a soapy water solution.
- 8. Replace wheels, remove safety stands and carefully lower vehicle to ground.
- 9. Deflate Air Springs in 5 psi intervals to determine

best ride and handing. Sufficient air pressure should be maintained to help prevent bottoming-out on large bumps, chuck holes, etc.

10. Recheck air pressure after 24 hours. A 2-4 psi loss is normal after initial installation. If the pressure has dropped more than 5 psi re-test for leaks with a soapy water solution. Please read and follow the Maintenance and Operation Tips on page 4.

FAILURE TO MAINTAIN MINIMUM PRESSURE WILL VOID THE WARRANTY

MINIMUM AIR PRESSURE 5 PSI	MAXIMUM AIR PRESSURE 35 PSI
<p>MAINTENANCE TIPS:</p> <ol style="list-style-type: none"> 1. Check pressure weekly! 2. Always maintain at least 5 psi air pressure chafing or coil pinch. 3. If you develop an air leak in the system, use a soapy solution to check all air line connections and the valve core before removing cylinder. <p>OPERATING TIPS:</p> <ol style="list-style-type: none"> 1. Inflate your air springs to 35 psi before adding the payload. After vehicle is loaded, adjust your air pressure (down) to level the vehicle and for ride comfort. 2. Check your tire pressures and inflate according to manufacturers recommendations. 	
	<p><i>Thank you for purchasing Air Lift Products</i></p> <p>AIR LIFT COMPANY P.O. BOX 80167 Lansing, MI 48908-0167</p> <p><small>Printed in the USA</small></p>
<p>FOR TECHNICAL ASSISTANCE CALL 1-800-248-0892</p>	
<p>Caution: DO NOT EXCEED THE VEHICLE MANUFACTURERS MAXIMUM GROSS VEHICLE WEIGHT RATING.</p>	



Product Use Information

Frequently asked questions

Q. Will installing air springs increase the weight ratings of a vehicle?

No. Adding air springs will not change the weight ratings (GAWR, GCWR and/or GVWR) of a vehicle. Exceeding the GVWR is dangerous and voids the Air Lift warranty.

Q. Is it necessary to keep air in the air springs at all time and how much pressure will they need?

The minimum air pressure should be maintained at all times. The minimum air pressure keeps the air spring in shape, ensuring that it will move throughout its travel without rubbing or wearing on itself.

Q. Is it necessary to add a compressor system to the air springs?

No. Air pressure can be adjusted with any type of compressor as long as it can produce sufficient pressure to service the springs. Even a bicycle tire pump can be used, but it's a lot of work.

Q. How long should air springs last?

If the air springs are properly installed and maintained they can last indefinitely.

Q. Will raising the vehicle on a hoist for service work damage the air springs?

No. The vehicle can be lifted on a hoist for short-term service work such as tire rotation or oil changes. However, if the vehicle will be on the hoist for a prolonged period of time, support the axle with jack stands in order to take the tension off of the air springs.

Tuning the air pressure

Pressure determination comes down to three things — level vehicle, ride comfort, and stability.

1. Level vehicle

If the vehicle's headlights are shining into the trees or the vehicle is leaning to one side, then it is not level (fig. 1). Raise the air pressure to correct either of these problems and level the vehicle.

2. Ride comfort

If the vehicle has a rough and harsh ride it may be due to either too much pressure or not enough (fig. 2). Try different pressures to determine the best ride comfort.

3. Stability

Stability translates into safety and should be the priority, meaning the driver may need to sacrifice a perfectly level and comfortable ride. Stability issues include roll control, bounce, dive during braking and sponginess (fig. 3). Tuning out these problems usually requires an increase in pressure.

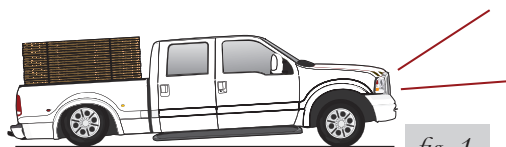

Bad headlight aim

fig. 1



Sway and body roll

fig. 2



Rough ride

fig. 3

Guidelines for adding air:

1. Start with the vehicle level or slightly above.
2. When in doubt, always add air.
3. For motorhomes, start with 50-100 PSI in the rear because it can be safely assumed that it is heavily loaded.
4. If the front of the vehicle dives while braking, increase the pressure in the front air bags, if equipped.
5. If it is ever suspected that the air bags have bottomed out, increase the pressure (fig. 4).
6. Adjust the pressure up and down to find the best ride.
7. If the vehicle rocks and rolls, adjust the air pressure to reduce movement.
8. It may be necessary to maintain different pressures on each side of the vehicle. Loads such as water, fuel, and appliances will cause the vehicle to be heavier on one side (fig. 5). As much as a 50 PSI difference is not uncommon.

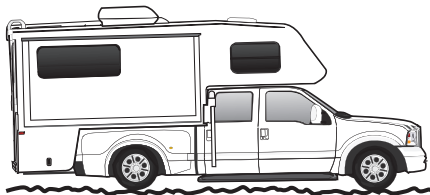

Bottoming out

fig. 4

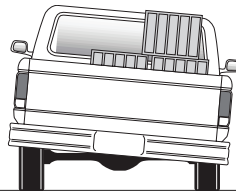

Unlevel

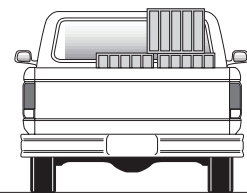

Level

fig. 5

Warranty and Returns Policy

Air Lift Company warrants its products, for the time periods listed below, to the original retail purchaser against manufacturing defects when used on catalog-listed applications on cars, vans, light trucks and motorhomes under normal operating conditions for as long as Air Lift manufactures the product. The warranty does not apply to products that have been improperly applied, improperly installed, used in racing or off-road applications, used for commercial purposes, or which have not been maintained in accordance with installation instructions furnished with all products. The consumer will be responsible for removing (labor charges) the defective product from the vehicle and returning it, transportation costs prepaid, to the dealer from which it was purchased or to Air Lift Company for verification.

Air Lift will repair or replace, at its option, defective products or components. A minimum \$10.00 shipping and handling charge will apply to all warranty claims. Before returning any defective product, you must call Air Lift at (800) 248-0892 in the U.S. and Canada (elsewhere, (517) 322-2144) for a Returned Materials Authorization (RMA) number. Returns to Air Lift can be sent to: Air Lift Company • 2727 Snow Road • Lansing, MI • 48917.

Product failures resulting from abnormal use or misuse are excluded from this warranty. The loss of use of the product, loss of time, inconvenience, commercial loss or consequential damages is not covered. The consumer is responsible for installation/reinstallation (labor charges) of the product. Air Lift Company reserves the right to change the design of any product without assuming any obligation to modify any product previously manufactured.

This warranty gives you specific legal rights and you may also have other rights that vary from state-to-state. Some states do not allow limitations on how long an implied warranty lasts or allow the exclusion or limitation of incidental or consequential damages. The above limitation or exclusion may not apply to you. There are no warranties, expressed or implied including any implied warranties of merchantability and fitness, which extend beyond this warranty period. There are no warranties that extend beyond the description on the face hereof. Seller disclaims the implied warranty of merchantability. (Dated proof of purchase required.)

Air Lift 1000	Lifetime Limited
RideControl	Lifetime Limited
SlamAir	Lifetime Limited
LoadLifter 5000*	Lifetime Limited
EasyStreet Systems	1 Year Limited

Load Controller (I)	2 Year Limited
Load Controller (II)	2 Year Limited
SmartAir	2 Year Limited
Wireless AIR	2 Year Limited
Other Accessories	2 Year Limited

**formerly SuperDuty*

TEMPLATE

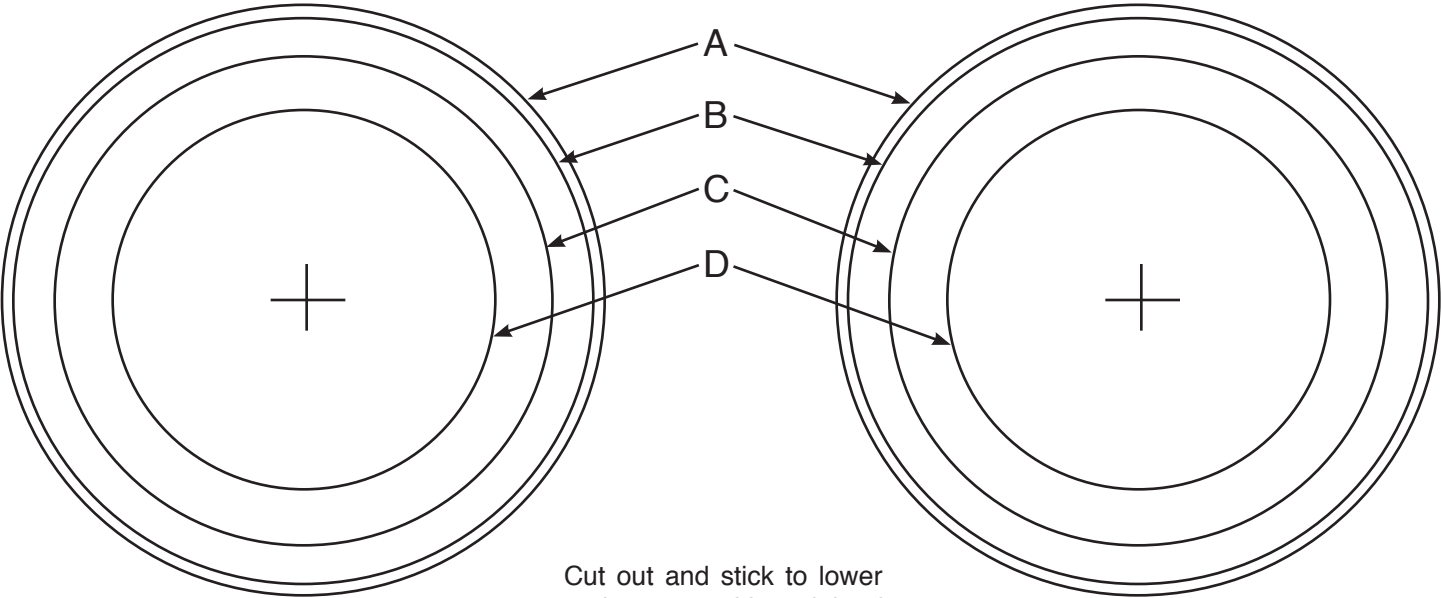

Cut out and stick to lower spring seat with a dab of grease.