

**\*\*DO NOT EXCEED RECOMMENDED VEHICLE TOWING WEIGHT!\*\***

# 60700 (60610 & 60651) FORD SUPERDUTY GOOSENECK SUBKIT

1/10/17

PAGE 1 OF 5

**WARNING!!** BRAKE, FUEL, AND ELECTRICAL LINES MAY NEED TO BE LOOSENED OR REPOSITIONED TO PROVIDE CLEARANCE FOR NEW HARDWARE. ALL MODELS REQUIRE MODIFICATION OR REMOVAL OF HEAT SHIELDS. ON SHORT BED MODELS, CHECK FOR ADEQUATE TURNING CLEARANCE BETWEEN THE FRONT OF ALL TRAILERS AND THE TRUCK CAB. ON TWO WHEEL DRIVE TRUCKS A CLEARANCE CHECK MUST BE PERFORMED WHEN TRUCK IS LOADED AND UNLOADED TO VERIFY THE INVERTED BALL WILL NOT INTERFERE WITH THE TOP OF THE DIFFERENTIAL



Hardware List			
ITEM	QTY	PART NUMBER	DESCRIPTION
1	16	5/8-11	HEX FLANGE NUT
2	4	5_8 - 11 x 4 HEX	HEX BOLT
3	4	5_8 WASHER	WASHER
4	8	9_16-12 x 1.5	GRADE 8 HEX BOLT
5	8	9/16" CONICAL WASHER	CONICAL TOOTHED WASHER
6	8	CM-SP74	.313 x 1.50 x 3.00" 9/16" SQUARE HOLE SPACER
7	12	5/8-11 x 1 3_4, GR8	CARRIAGE BOLT
8	4	CM-C113-UBS	U-BOLT SPRING
9	8	M16 WASHER	FLAT WASHER
10	2	60651-UB	5/8" SQUARE U-BOLT
11	4	5/8-18	CENTER LOCK NUT
12	1	CM-UE1	.300" U-SHAPED EDGING

Parts List			
ITEM	QTY	PART NUMBER	DESCRIPTION
A	1	60651-DS	DRIVER SIDE PLATE
B	1	60651-PS	PASSENGER SIDE PLATE
C	1	60651-DS2	DRIVER SIDE PLATE 2
D	1	60651-PS2	PASSENGER SIDE PLATE 2
E	1	60651-DSFWA	DRIVER SIDE FRONT WELDMENT
F	1	60651-PSF	PASSENGER SIDE FRONT PLATE
G	1	60651-DSR	DRIVER SIDE REAR PLATE
H	1	60651-PSR	PASSENGER SIDE REAR PLATE

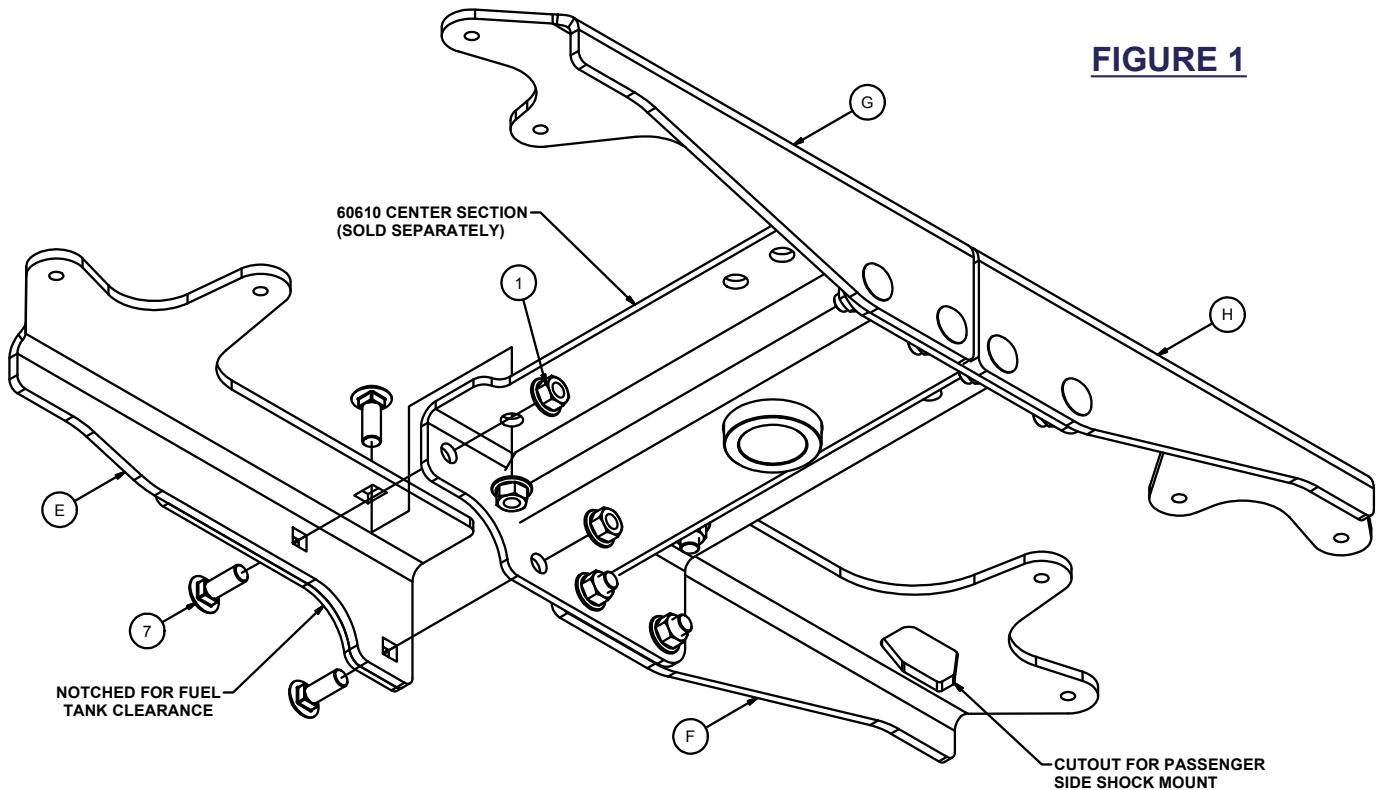

**FIGURE 1**

SUBKIT WEIGHT: 97 LBS.

INSTALL TIME

PROFESSIONAL: 75 MINUTES

NOVICE (DIY): 150 MINUTES

INSTALL NOTES:

- NO FRAME DRILLING REQUIRED
- NO MEASURING DRILL LOCATIONS
- NO LOWERING EXHAUST OR SPARE REQUIRED

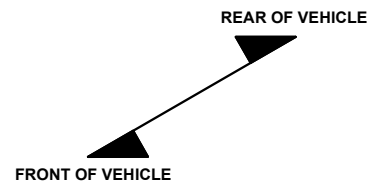

Scan for more information

**PERIODICALLY CHECK THIS RECEIVER HITCH TO ENSURE THAT ALL FASTENERS ARE TIGHT AND THAT ALL STRUCTURAL COMPONENTS ARE SOUND.**

CURT Manufacturing LLC., warrants this product to be free of defects in material and/or workmanship at the time of retail purchase by the original purchaser. If the product is found to be defective, CURT Manufacturing LLC., may repair or replace the product, at their option, when the product is returned, prepaid, with proof of purchase. Alteration to, misuse of, or improper installation of this product voids the warranty. CURT Manufacturing LLC.'s liability is limited to repair or replacement of products found to be defective, and specifically excludes liability for incidental or consequential loss or damage.

This product complies with safety specifications and requirements for connecting devices and towing systems of the state of New York, V.E.S.C.Regulation V-5 and SAE J684.

**\*\*DO NOT EXCEED RECOMMENDED VEHICLE TOWING WEIGHT!\*\***

# 60700 (60610 & 60651) FORD SUPERDUTY GOOSENECK SUBKIT

PAGE 2 OF 5

**WARNING!!**

BRAKE, FUEL, AND ELECTRICAL LINES MAY NEED TO BE LOOSENED OR REPOSITIONED TO PROVIDE CLEARANCE FOR NEW HARDWARE. ALL MODELS REQUIRE MODIFICATION OR REMOVAL OF HEAT SHIELDS. ON SHORT BED MODELS, CHECK FOR ADEQUATE TURNING CLEARANCE BETWEEN THE FRONT OF ALL TRAILERS AND THE TRUCK CAB. ON TWO WHEEL DRIVE TRUCKS A CLEARANCE CHECK MUST BE PERFORMED WHEN TRUCK IS LOADED AND UNLOADED TO VERIFY THE INVERTED BALL WILL NOT INTERFERE WITH THE TOP OF THE DIFFERENTIAL



**FIGURE 2**

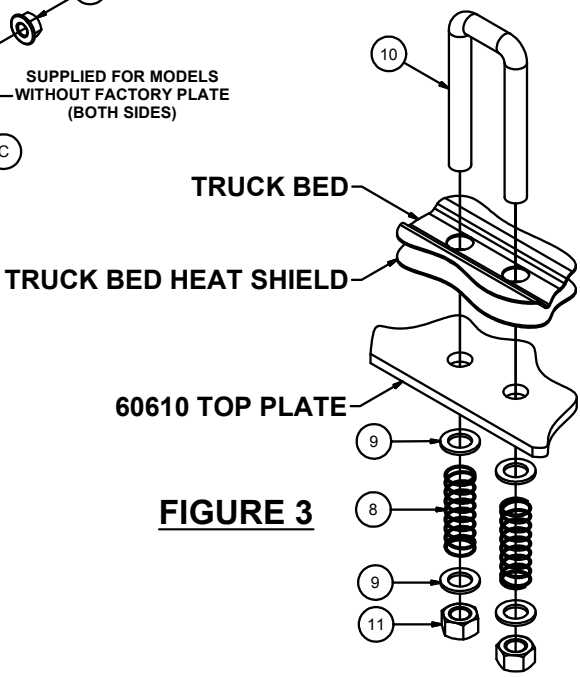
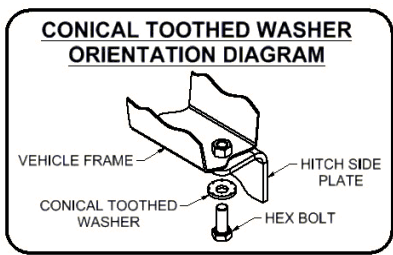
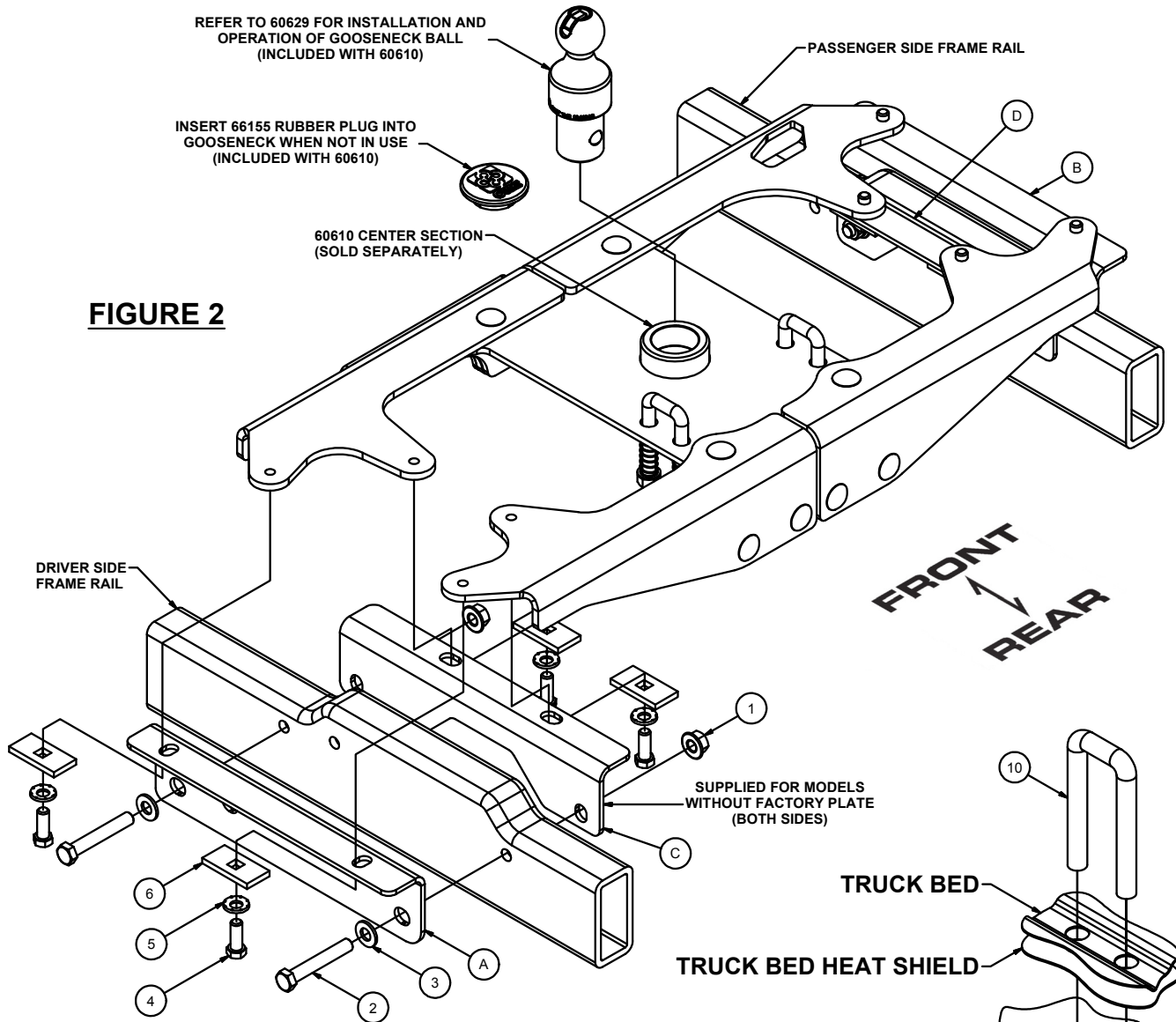

**FIGURE 3**

**PERIODICALLY CHECK THIS GOOSENECK HITCH TO ENSURE THAT ALL FASTENERS ARE TIGHT AND THAT ALL STRUCTURAL COMPONENTS ARE SOUND.**

CURT Manufacturing LLC., warrants this product to be free of defects in material and/or workmanship at the time of retail purchase by the original purchaser. If the product is found to be defective, CURT Manufacturing LLC., may repair or replace the product, at their option, when the product is returned, prepaid, with proof of purchase. Alteration to, misuse of, or improper installation of this product voids the warranty. CURT Manufacturing LLC.'s liability is limited to repair or replacement of products found to be defective, and specifically excludes liability for incidental or consequential loss or damage.

This product complies with safety specifications and requirements for connecting devices and towing systems of the state of New York, V.E.S.C.Regulation V-5 and SAE J684.

## **60700 (60610 & 60651) FORD SUPERDUTY GOOSENECK SUBKIT**

**WARNING!!**



BRAKE, FUEL, AND ELECTRICAL LINES MAY NEED TO BE LOOSENED OR REPOSITIONED TO PROVIDE CLEARANCE FOR NEW HARDWARE. ALL MODELS REQUIRE MODIFICATION OR REMOVAL OF HEAT SHIELDS. ON SHORT BED MODELS, CHECK FOR ADEQUATE TURNING CLEARANCE BETWEEN THE FRONT OF ALL TRAILERS AND THE TRUCK CAB. ON TWO WHEEL DRIVE TRUCKS A CLEARANCE CHECK MUST BE PERFORMED WHEN TRUCK IS LOADED AND UNLOADED TO VERIFY THE INVERTED BALL WILL NOT INTERFERE WITH THE TOP OF THE DIFFERENTIAL

### **INSTALLATION STEPS**

1. Removing the spare tire may aid in installation but is not required.
2. Check the area above the rear differential for any obstructions before drilling the 3 1/4" hole for the ball. From above the truck, drill a 3 1/4" hole through the bed of the truck using a hole saw with the factory dimple as a guide. Install the CM-UE1 rubber edge trim around the edge of the cut hole and trim to length.
3. From under the truck loosely install the frame attachment plates (items A, B, C, and D in the parts list) to the frame as shown in **FIGURE 2**.
4. Place (1) 5/8" carriage bolt into the top mounting hole of each center attachment plate (items E, F, G, and H in the parts list). Referring to FIGURE 1, place the center attachment plates into position. Loosely install all of the 9/16" bolts, conical lock washers and spacers as shown in **FIGURE 2**.

Note: the location and orientation of each center attachment plate.

5. Raise the center section (60610 not included) between the drive shaft and the exhaust on the passenger side of the vehicle in front of the rear axle if the spare was not lowered. Align the 5/8" carriage bolts in the center attachment plates with the rectangular holes. Make sure the notched corner of the center section is positioned over the fuel tank. Loosely install the supplied 5/8" hex flange nuts.
6. Align the gooseneck ball cylinder with the hole drilled in the bed in step 2. Push the center section up to the bottom of the truck bed and insert the remaining 5/8" carriage bolts as shown in **FIGURE 1**. Install remaining 5/8" hex flange nuts.
7. Torque all 9/16" fasteners to 150 lbs.-ft. and all 5/8" fasteners to 212 lbs.-ft.
8. Using the center section as a template, drill the 4 holes needed through the heat shield and truck bed for the safety chains using an 11/16" drill bit. Note drilling a small pilot hole prior to the 11/16" hole will ease this process. Drill must be perpendicular to the heat shield and bed.
9. Install the safety chain U-bolt assemblies as shown in **FIGURE 3**, ensure they sit flat when in the lower position and slide easily without binding. Enlarge holes as needed for proper operation. Deburr holes and spray exposed metal with rust inhibitor. The nuts should be tightened until flush with the bottom of the U-bolt.
10. Reinstall the spare tire if removed in step 1.

**PERIODICALLY CHECK THIS GOOSENECK HITCH TO ENSURE THAT ALL FASTENERS ARE TIGHT AND THAT ALL STRUCTURAL COMPONENTS ARE SOUND.**

CURT Manufacturing LLC., warrants this product to be free of defects in material and/or workmanship at the time of retail purchase by the original purchaser. If the product is found to be defective, CURT Manufacturing LLC., may repair or replace the product, at their option, when the product is returned, prepaid, with proof of purchase. Alteration to, misuse of, or improper installation of this product voids the warranty. CURT Manufacturing LLC.'s liability is limited to repair or replacement of products found to be defective, and specifically excludes liability for incidental or consequential loss or damage.

This product complies with safety specifications and requirements for connecting devices and towing systems of the state of New York, V.E.S.C.Regulation V-5 and SAE J684.

# CAB TO TRAILER CLEARANCE

**\*\*\*DO NOT EXCEED VEHICLE MANUFACTURER'S RECOMMENDED TOWING CAPACITY.\*\*\***

HAVING INSTALLATION QUESTIONS? CALL TECHNICAL SUPPORT AT 1-800-798-0813

**\*\*REMOVAL OF REAR WINDOW ACCESSORIES MAY BE REQUIRED\*\***

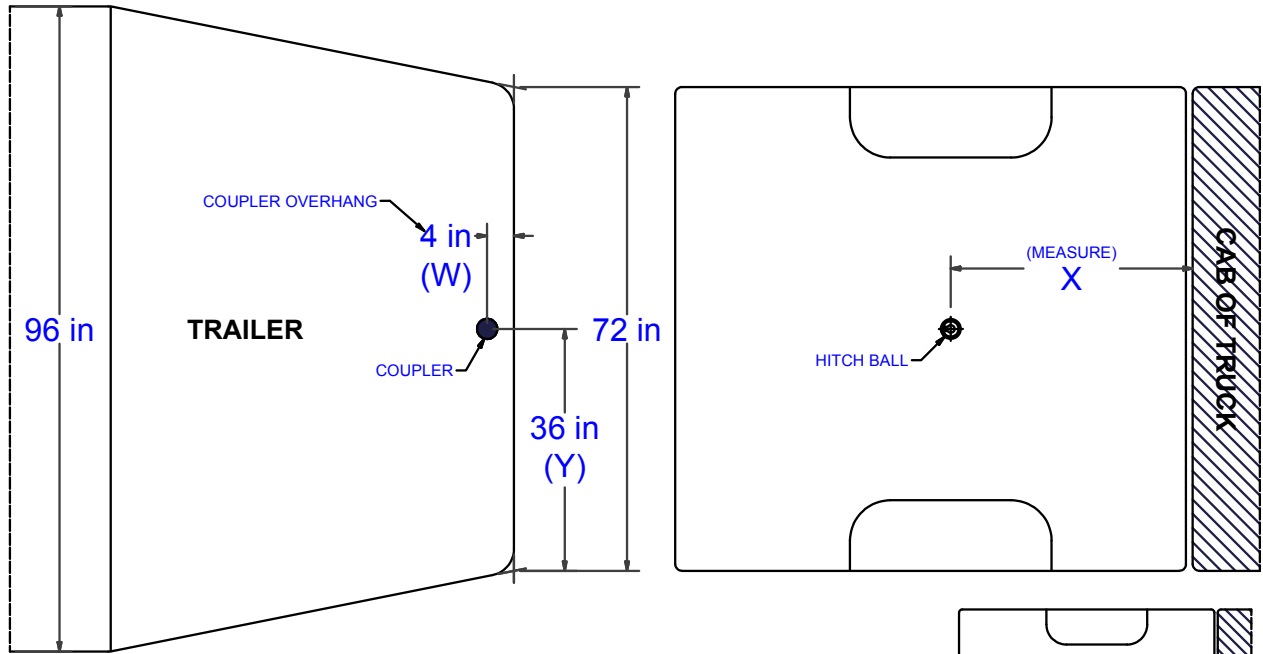

**\*\*GENERALLY, TAPERED NOSE TRAILERS ADHERE TO THE FOLLOWING DESIGNS:\*\***  
 8 FT. WIDE TRAILERS TAPER TO 6 FT. AT THE COUPLER  
 7 FT. WIDE TRAILERS TAPER TO 5 FT. AT THE COUPLER

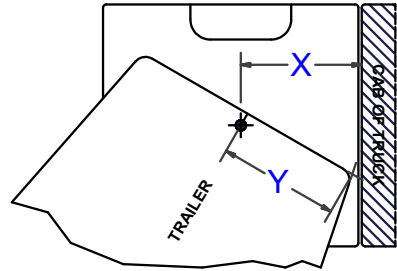

## CLEARANCE CALCULATION

$$\begin{matrix} \text{(CAB TO BALL CENTER)} & - & 1/2 \text{ (TRAILER WIDTH)} & = & \text{(MINIMUM CLEARANCE)} \\ \text{(X)} & & \text{(Y)} & & \text{(Z)} \end{matrix}$$

IF THERE IS AN OVERHANG FROM THE COUPLER THEN THE EQUATION IS:

$$\text{[(X) - (W)]} - \text{(Y)} = \text{(Z)}$$

**\*\*\*IF (Z) IS POSITIVE, TRAILER WILL NOT INTERFERE WITH CAB OF TRUCK.\*\*\***  
**IF (Z) IS NEGATIVE, TRAILER WILL INTERFERE WITH CAB OF TRUCK!!!**

### EXAMPLE:

#### STANDARD TRAILER

$$\begin{aligned} X - Y &= Z \\ 35 - 36 &= -1 \\ \text{(TRAILER WILL INTERFERE WITH CAB)} \end{aligned}$$

#### TRAILER WITH OVERHANG

$$\begin{aligned} [(X) - (W)] - Y &= Z \\ [35 - 4] - 36 &= -5 \\ \text{(TRAILER WILL INTERFERE WITH CAB)} \end{aligned}$$

### YOUR CALCULATION:

(CAB TO BALL CENTER) \_\_\_\_\_

(COUPLER OVERHANG) \_\_\_\_\_

1/2 (TRAILER WIDTH) \_\_\_\_\_

(MINIMUM CLEARANCE) \_\_\_\_\_

**PERIODICALLY CHECK THIS RECEIVER HITCH TO ENSURE THAT ALL FASTENERS ARE TIGHT AND THAT ALL STRUCTURAL COMPONENTS ARE SOUND.**

CURT Manufacturing LLC., warrants this product to be free of defects in material and/or workmanship at the time of retail purchase by the original purchaser. If the product is found to be defective CURT Manufacturing LLC., may repair or replace the product, at their option, when the product is returned, prepaid, with proof of purchase. Alteration to, misuse of, or improper installation of this product voids the warranty. CURT Manufacturing LLC.'s liability is limited to repair or replacement of products found to be defective, and specifically excludes liability for incidental or consequential loss or damage.

# IMPORTANT TOWING INFORMATION

PAGE 5 OF 5

**\*\*\*DO NOT EXCEED VEHICLE MANUFACTURER'S RECOMMENDED TOWING CAPACITY.\*\*\***

HAVING INSTALLATION QUESTIONS? CALL TECHNICAL SUPPORT AT 1-800-798-0813

## **BEFORE TOWING THE FIRST TIME:**

- Verify adequate turning clearance between the truck cab / box corners and trailer(s).
- Check truck box clearance. There should be a minimum clearance of 6" between the bottom of the trailer(s) overhang and the top of the box sides.
- Verify all hardware is torqued to the proper specification.
- Verify the trailer safety chain length. Too much slack in the chain may prevent maintaining control in the event of separation. Leave only enough slack to allow full turning without interference.
- Verify the trailer attachments to the safety chain loops are secure (cannot be shaken free during towing).

## **MAINTENANCE:**

- Keep gooseneck ball, receiver, and trailer coupler lubricated regularly. Use silicone spray or equivalent to prevent wear / rust.
- Keep gooseneck ball, receiver, and trailer coupler free of dirt and other foreign debris.  
**Note:** Failure to maintain your towing system could result in poor performance and/or catastrophic failure.

## **BEFORE TOWING EVERY TIME:**

- Ensure all fasteners are tight and that all structural components are sound.  
**Note:** Do not tow trailer with worn or damaged parts.
- Attach trailer securely to safety chain loops.
- Ensure the trailer weight does not exceed any part of your towing system. Be sure load is heavier towards front of the trailer while not exceeding the hitch tongue weight. Be sure trailer load is secured to prevent shifting and centered from left to right. **Note:** Never load the trailer heavier behind the trailer axle(s).
- Check tires to ensure they are inflated to the proper specification. Follow vehicle and trailer recommendations.
- Verify trailer lights, electric brakes, and breakaway switches are working properly.

## **WARNING!!**

- Vehicle performance (braking, handling, acceleration, turning radius) can be drastically affected by the trailer. Allow additional time / space for stopping, changing lanes, passing and turning.
- Do not tow more than one trailer at a time. This may cause loss of control.
- Severe bumps can damage your towing system. Avoid or drive slowly over rough terrain.

**PERIODICALLY CHECK THIS RECEIVER HITCH TO ENSURE THAT ALL FASTENERS ARE TIGHT AND THAT ALL STRUCTURAL COMPONENTS ARE SOUND.**

CURT Manufacturing LLC., warrants this product to be free of defects in material and/or workmanship at the time of retail purchase by the original purchaser. If the product is found to be defective CURT Manufacturing LLC., may repair or replace the product, at their option, when the product is returned, prepaid, with proof of purchase. Alteration to, misuse of, or improper installation of this product voids the warranty. CURT Manufacturing LLC.'s liability is limited to repair or replacement of products found to be defective, and specifically excludes liability for incidental or consequential loss or damage.