

Installation Instructions

Round Bar Weight Distribution With Sway Control 49901IN

Part Numbers:
49901
49902
49903

DEALERS: Please give these instructions to your customer.

Do Not Exceed Lower of Towing Vehicle
Manufacturer's Rating or

Equipment Required:

Wrenches: 9/16", 3/4", 1-1/8"

Drill Bits: 11/32"

Torque Wrench capable of reading 260 ft-lbs.

Hitch Part Number 49901	Max Gross Trailer WT (LB)	Max Tongue WT (LB)
Weight Distributing	10,000	550
Weight Carrying Ball Mount	5,000	500

Hitch Part Number 49902	Max Gross Trailer WT (LB)	Max Tongue WT (LB)
Weight Distributing	10,000	750
Weight Carrying Ball Mount	5,000	500

Hitch Part Number 49903	Max Gross Trailer WT (LB)	Max Tongue WT (LB)
Weight Distributing	10,000	1,000
Weight Carrying Ball Mount	5,000	500

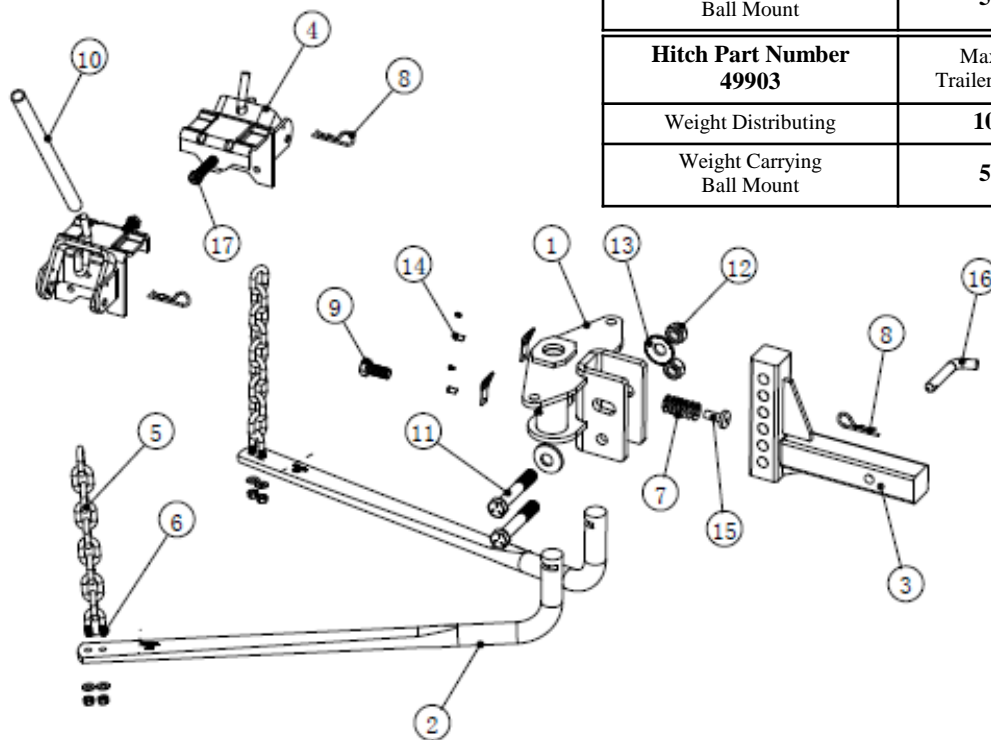

For Installation Assistance or Technical Help, Call 1-888-521-0510

①	Qty. (1)	BALL MOUNT	⑩	Qty. (1)	LIFTER HANDLE
②	Qty. (2)	SPRING BAR	⑪	Qty. (2)	3/4"-10 X 4 1/2" BOLTS
③	Qty. (1)	HITCH BAR	⑫	Qty. (2)	3/4"-10 NUT
④	Qty. (2)	SNAPUP BRACKET	⑬	Qty. (2)	3/4" CONICAL WASHER
⑤	Qty. (2)	SAFETY CHAIN	⑭	Qty. (2)	SPRING BAR LOCK ASSEMBLY
⑥	Qty. (2)	3/8" U-BOLT, NUT, & WASHER	⑮	Qty. (1)	RIVET
⑦	Qty. (7)	SPACER WASHER	⑯	Qty. (1)	PULL PIN
⑧	Qty. (3)	SPRING CLIP	⑰	Qty. (2)	SNAP UP BRACKET SET SCREW
⑨	Qty. (1)	SET SCREW			

Installation Instructions

Round Bar Weight Distribution With Sway Control

49901IN

Part Numbers:

49901
49902
49903

INDEX

1. SIZING WD AND TRAILER HITCH SYSTEMS	P. 1
2. INITIAL SET UP	P. 1 - 2
3. INITIAL HOOK UP	P. 2 - 4
4. SWAY CONTROL	P. 5
5. SWAY CONTROL INSTALLATION	P. 6
SWAY CONTROL HOOK-UP	
SWAY CONTROL ADJUSTMENT	
SWAY CONTROL UNHOOKING	
6. WARNINGS	P. 7
7. TOWING TIPS	P. 7
8. NOTES	P. 8
9. 5 YEAR LIMITED WARRANTY	P. 8

WARNING:

Failure to follow all of these instructions may result in death or serious injury!

SIZING WD AND TRAILER HITCH SYSTEMS

1. Refer to provided Consumer Information to weigh loaded trailer tongue to determine proper system size.
2. Choose a system with tongue rating at or above the actual trailer tongue weight
3. Tongue rating of trailer hitch must meet or exceed measured tongue weight of trailer. OEM hitches may not be rigid enough for tongue weight and may need to be replaced (too much flex and won't carry load).
4. Total trailer gross weight rating must never exceed tow vehicle rated gross tow rating.

INITIAL SET-UP

1. Line up tow vehicle and trailer on level pavement, in straight-ahead position, uncoupled.
2. Level the trailer and measure and record the distance from the ground to the top of the coupler. (Fig.1).

WARNING: Raised balls usually have reduced load ratings. Ball rating MUST equal or exceed trailer GVWR.

Note: Numbers in circles can be found in the chart on page (1)

3. Some installations may require a longer hitch bar ③ . Extended bumper guards, pickup truck "caps", or rear mounted spare tires can limit turn angles unless a longer bar is used. Individual hitch bars ③ are available in various sizes.
4. Insert the hitch bar ③ into the hitch box and install a pull pin ⑥ and gold spring clip ⑨ . Hitch bar ③ may be used in either the up or down position (see Fig. 2).

NOTE: The ball height should be greater than coupler height by approximately 3/4 to 1" (measured in step 2) to compensate for vehicle squat. For vehicles with air springs, air shocks or an automatic leveling system, check vehicle owners manual. Unless otherwise specified, level the trailer with the vehicle loaded as it will be when towing before setting ball height and attaching trailer.

Installation Instructions

Part Numbers:

Round Bar Weight Distribution With Sway Control

49901

49901IN

49902

49903

5. Slide hitch bar into sleeve receiver; insert hitch pin and gold spring clip. With ball attached to ball mount, slide ball mount up or down hitch bar (hitch bar may be used in the up or down position) until nearest dimension is obtained and holes line up with hitch bar. Insert bolt in bottom hole first (rest hitch head.)

6. Rivet ⑤ and 8 spacer washers ⑦ are supplied in order to gain correct downward angle of spring bars. Insert rivet ⑤, and depending on angle or slope of bars that must be gained, use either 8 or the least amount of washers ⑦ necessary in order to establish correct angle. (See Fig. 1, 2, and 3 below.)

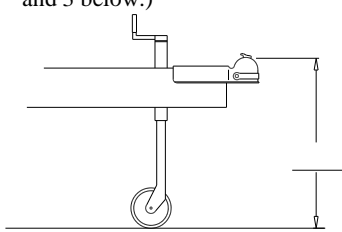

Fig. 1

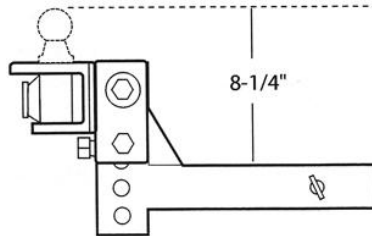
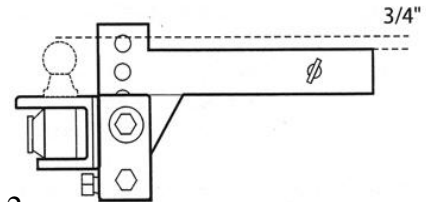

Fig. 2



7. The rivet ⑤ and its accompanying washers ⑦ are placed in the 1/2" hole between the "U" on ball mount ① to acquire desired angle of spring bar ②. Once spring bar ② angle has been determined, insert top bolt ⑩ with serrated washer ③. Install second serrated washer ③ and nut ② to secure unit in correct position. Before tightening bolts, lock set screw ⑨. Tighten the 3/4" top bolt ⑩ to 260 ft. lbs. torque once head angle is set. Secure lower bolt ⑩ to 260 ft. lbs. torque. After first day of towing, check set screw ⑨ for tightness.

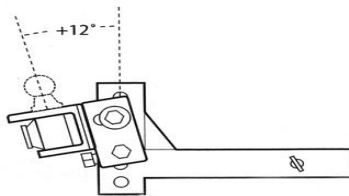
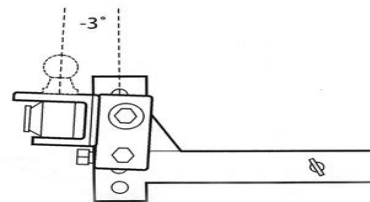

Fig. 3



EACH WASHER LOWERS CHAIN END OF SPRING BAR APPROX 1-1/2"

INITIAL HOOK-UP

NOTE: Tow Vehicle and trailer should be loaded and ready for travel before final leveling.

1. Pick a reference point on the front wheel well. Measure and record distance to pavement.
Front wheel well to pavement _____
2. Using tongue jack, lower coupler onto ball and close coupler latch.
3. The Spring Bars can be inserted into either side of Ball Mount (there is no 'right' or 'left bar'). To lock, insert and lock Spring Bar in socket, hold bar under socket and push up. The Spring Bar will automatically be locked into position by the Spring Bar Locking Device. (Check to make sure bar is locked in by moving it up and down at the chain end.)
4. To remove Spring Bars, just pull out on the locking device or swing bar around under the bumper and it will drop free.

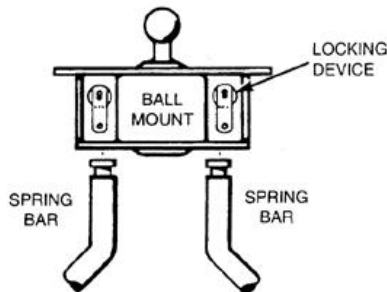

5. Position the snap up brackets on trailer "A" frame so that the chain on the end of the spring bar is approximately vertical. Turn set-screw until it contacts frame. Then tighten 1/4 turn with wrench. **DO NOT OVERTIGHTEN.**

Installation Instructions

Round Bar Weight Distribution With Sway Control

49901IN

Part Numbers:

49901

49902

49903

6. Raise trailer tongue and rear of vehicle with the tongue jack. Approximately 8-12 inches. Lower yoke of snap up bracket until it is parallel with the ground, and slip the closest link over the hook (If there are less than 5 links between hook and u-bolt adjust ballmount angle rearward, and repeat procedure - see Fig. 1 to 4 below). With the snap up bracket handle over the yoke, raise until yoke has passed "over-center". Slide the silver safety pin through the small hole to lock the yoke in place. Repeat for other side.

BEFORE HOOKING UP

Spring bars should hang down on a 10° to 13° angle when ball mount has been tilted back at 6° to 8° angle.

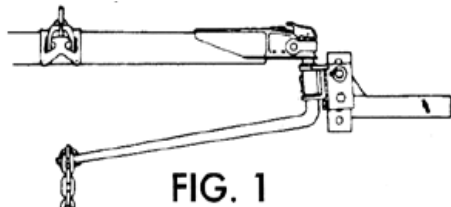

AFTER HOOKING UP

Spring bar should be parallel with trailer frame, or a slight angle up or down.

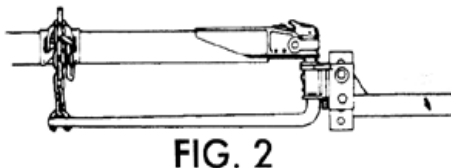

WRONG

Readjust degree of tilt on ball mount, if you have more than 5 links of chain hanging free. The number of links should be the same on both bars.

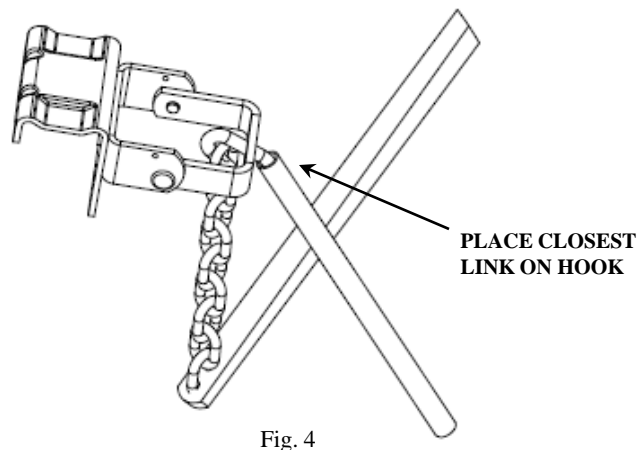
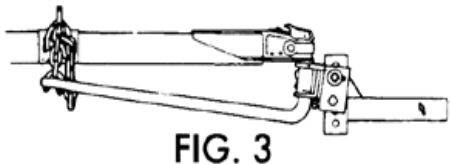

7. Lower jack. Re-measure front wheel well reference point. The front wheel well height should be equal to or lower than the original measurement. If the front wheel well height is higher than originally measured, reduce the number of links between the yoke hook and spring bar (5 links min.) and recheck the wheel well measurement. If the front wheel well is lower than originally measured, increase the number of chain links between the yoke hook and spring bar and recheck the wheel well measurement. If the original wheel well height is not achievable, it is preferred that the wheel well height is lower after the spring bars are loaded. If there are no more chain links for adjustment, the head assembly must be tilted forward. The trailer must be uncoupled and the upper bolt removed from the head assembly. The head is then pivoted up as appropriate. Reassemble and recheck the wheel well height.

LUBRICATION

1. **MAINTENANCE:** Use heavy lubrication such as fiber type wheel bearing grease on hitch ball and on spring bars. Recommended every day. Keep hitch painted to prevent rust and check tightness of bolts regularly. Clean out old grease, do not let it harden inside of the Ball Mount.

SURGE BRAKES

1. Some surge brakes will not work with weight distributing hitches. CHECK TRAILER AND/OR SURGE BRAKE OPERATING INSTRUCTIONS FOR ANY SPECIAL REQUIREMENTS REGARDING WEIGHT DISTRIBUTING HITCHES.
Do not use sway control with surge brakes.

Installation Instructions

Round Bar Weight Distribution With Sway Control

49901IN

Part Numbers:

49901
49902
49903

SWAY CONTROL

Please read all instructions carefully before assembly, installation and/or use of this product.

WARNING:

You change the characteristics of a tow vehicle by towing a trailer
 When towing a trailer, you may find more sway in short wheel base vehicles. Exercise extra CAUTION.
 Any welding should be done by a qualified welding shop.

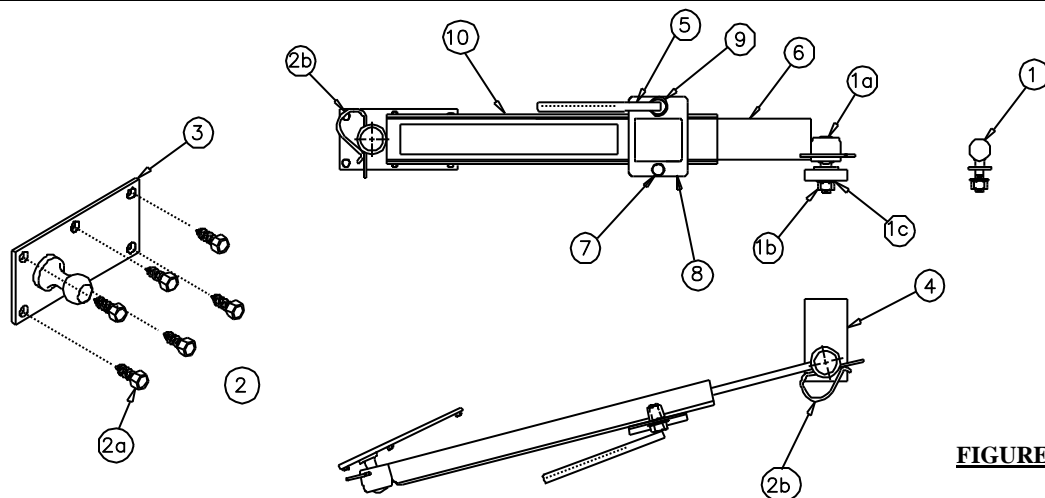

FIGURE 1

REF. QTY.	DESCRIPTION	REF. QTY.	DESCRIPTION
1	1 Ball Assembly	4	1 Bar - Ball Mounting (sold separately)
1a	1 Ball	5	1 Handle, On/Off
1b	1 Nut, Hex, 5/8"-11	6	1 Slide Bar
1c	1 Lock Washer	7	1 Bolt, Tension Adjusting
2	1 Fastener Kit	8	1 Compression Plate Ass'y
2a	6 Screw, Self Tapping 24-9 X 1"	9	1 Washer, Hardened
2b	2 Clip	10	1 Main Body Ass'y
3	1 Ball/Plate Assembly		

IMPORTANT

1. **SWAY CONTROL CANNOT BE USED ON TRAILERS WITH SURGE BRAKES. DO NOT USE SWAY CONTROL ON CLASS I HITCHES.**
2. Trailer loading: Proper trailer loading is your first-line of defense against dangerous instability and sway. Heavy items should be placed on the floor in front of the axle. The load should be balanced side-to-side and secured to prevent shifting. Tongue weight should be about 10-15 percent of gross trailer weight for most trailers. Too low a percentage of tongue weight can cause sway. Load the trailer heavier in front.
3. The handle (5) is an on/off device. The bolt (7) below is for adjustment only.
4. When towing during slippery conditions such as wet, icy, or snow-covered roads or on loose gravel, turn on/off handle (5) counterclockwise until all tension is removed from unit. Failure to do so could prevent tow vehicle and trailer from turning properly.
5. Do not speed up if sway occurs. Sway increases with speed. Do not continue to operate a swaying vehicle. Check trailer loading, sway control adjustment and all other equipment until the cause of sway has been determined and corrected.
6. Never paint or lubricate slide bar (6).

Installation Instructions

Round Bar Weight Distribution With Sway Control

49901IN

Part Numbers:

49901

49902

49903

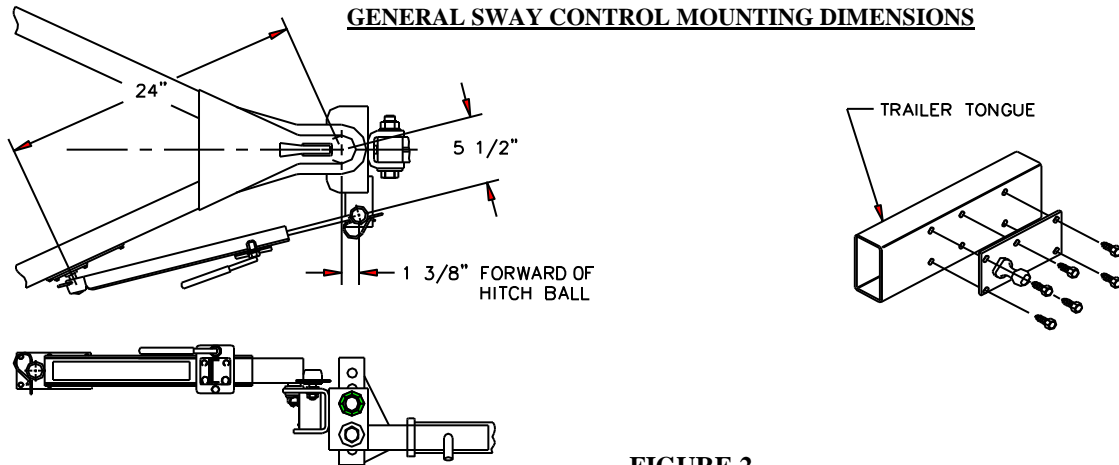

SWAY CONTROL INSTALLATION

1. Refer to Figures 1 and 2

- a. Connect trailer to tow vehicle. Position vehicle and trailer in a straight line on a level surface.
- b. Mount sway control ball (1a) using nut (1b) and lock washer (1c) to hitch as shown in Figure 2 and torque to 100 lb.-ft. If necessary notch and weld ball mounting bar (4) (sold separately) into position shown.
- c. Measure and mark a point on the trailer tongue 24" from the center of the hitch ball as shown in Figure 2.
- d. Align the center of the ball of the ball/plate assembly (3) with the mark on the trailer tongue and center punch four hole locations. Drill four holes using an 11/32 (.343) drill bit for 1/8" (.125) or thicker trailer tongue material, or a 9/32 (.281) drill bit for thinner material.
- e. Position the ball/plate assembly (3) over the drilled holes and drive four of the self tapping screws (2a) through the plate and into the trailer tongue. Drill the two remaining holes and install the screws.

NOTE: For left hand installation, remove slide bar (6), and reinstall upside down.

2. HOOK-UP

- a. Lubricate both balls with a small amount of grease, place socket of slide bar (6) over ball (1) and secure with gold clip (2b). Loosen handle (5) until the slide bar can be moved. Extend sway control assembly and place socket over ball on trailer, secure with other gold clip (2b).
- b. Retighten handle until it stops.
- c. On some installations, damage to the sway control may occur during extremely sharp turning maneuvers. This can be checked by slowly backing vehicle into a jackknife position while someone is watching. Do not allow slide bar to contract completely (bottom out) or bumper to contact sway control. If it looks as though contact will be made or the sway control will bottom out then the sway control must be removed before backing trailer.

3. ADJUSTMENT

- a. Trailer configurations and loading, road and weather conditions, towing speed, tire condition and pressure, and center of gravity of trailer all affect towing. To get maximum benefits from the sway control assembly, a series of road tests should be taken with the loaded trailer. On subsequent trips increase or decrease tension by turning the adjusting bolt (7) in 1/4 turn increments in the direction shown on the label until the desired control is achieved. For large trailers, it may be necessary to install a second sway control unit.
- b. After about 1000 miles of towing, remove the slide bar from the sway control and clean the friction surfaces with a wire brush. Repeat this cleaning procedure about every 10,000 miles.

4. UNHOOKING

- a. Release tension by turning on/off handle counterclockwise.
- b. Remove both clips (2b), remove sway control.

Installation Instructions

Part Numbers:

Round Bar Weight Distribution With Sway Control 49901IN

49901

49902

49903

WARNINGS: LOADED BALL HEIGHT SHOULD NOT BE GREATER THAN UNCOUPLED BALL HEIGHT. Front wheel overload and loss of rear wheel traction can result, and can lead to unstable handling, reduced braking ability, and a tendency to "jackknife" when turning and braking at the same time. IF LOADED BALL HEIGHT IS GREATER THAN UNCOUPLED HEIGHT, reduce take-up on spring bar chains and re-measure until proper height is obtained.

DO NOT TOW MULTIPLE TRAILERS: Do not attempt to tow any type of trailer behind another trailer. Towing multiple trailers may cause severe instability, loss of control and/or structural failure, and may result in vehicle accident, property damage and personal injury. Towing multiple trailers is illegal in many jurisdictions.

FRONT-WHEEL-DRIVE VEHICLES: DO NOT ATTEMPT TO HOOK-UP OR TOW WITH REAR WHEELS OF TOWING VEHICLE REMOVED. Severe structural damage to towing vehicle, hitch, and trailer may result. A towing vehicle/trailer combination cannot be controlled adequately unless the towing vehicle's rear wheels are carrying their share of the load.

MAINTENANCE: Keep sockets in head assembly free of dirt and well lubricated. Excessive wear in this area may indicate overload or inadequate lubrication.

Keep head assembly exterior clean, especially the spring bar sockets. Do not allow dirt or stones to lodge between spring bar and head.

Keep hitch painted to prevent rust and maintain a good appearance. (Do not paint over labels)

AT THE BEGINNING OF EVERY TOWING DAY:

- Clean ball and coupler socket and coat ball lightly with grease.
- Check spring bar chains and U-bolts for wear. Replace before they become worn halfway through.
- Check to see that all bolts are properly tightened and hitch pin and clip are securely in place.
- Check to see that electrical hookups are in working order, and that safety chains are connected.

TOWING TIPS

DRIVING: Good habits for normal driving need extra emphasis when towing. The additional weight affects acceleration and braking, and extra time should be allowed for passing, stopping, and changing lanes. Signal well in advance of a maneuver to let other drivers know your intentions. Severe bumps and badly undulating roads can damage your towing vehicle, hitch, and trailer, and should be negotiated at a slow steady speed. IF ANY PART OF YOUR TOWING SYSTEM "BOTTOMS" OUT, OR IF YOU SUSPECT DAMAGE MAY HAVE OCCURED IN ANY OTHER WAY, PULL OVER AND MAKE A THOROUGH INSPECTION. CORRECT ANY PROBLEMS BEFORE RESUMING TRAVEL.

CHECK YOUR EQUIPMENT: Periodically check the condition of all your towing equipment and keep it in top condition.

TRAILER LOADING: Proper trailer loading is important. Heavy items should be placed close to the floor near the trailer axle. The load should be balanced side-to-side and firmly secured to prevent shifting. Tongue weight should be about 10-15 percent of the gross trailer weight for most trailers. Too low a percentage of tongue weight will often produce a tendency to sway. Excess weight on the tongue can also lead to sway and damage hitch and / or tow vehicle.

SWAY CONTROLS: A sway control can help minimize the affects of sudden maneuvers, wind gusts, and buffeting caused by other vehicles. Use of a sway control is recommended for trailers with large surface areas, such as travel trailers.

TIRE INFLATION: Unless specified otherwise by the towing vehicle or trailer manufacturer, tires should be inflated to their maximum recommended pressure.

TOWING VEHICLE AND TRAILER MANUFACTURERS' RECOMMENDATIONS: Review the owners' manuals for your towing vehicle and trailer for specific recommendations, capacities, and requirements.

POLE TONGUE TRAILERS: If your trailer has a straight tongue (instead of an A-frame tongue), it will be necessary to use a pole tongue adapter. This adapter attaches to the trailer tongue, providing a place to attach the snap up brackets.

PASSENGERS IN TRAILERS: Trailers should NOT be occupied while being towed, under any circumstances.

TRAILER LIGHTS, TURN SIGNALS, AND ELECTRIC BRAKES: Always hook up trailer lights, turn signals, electric brakes and break-away switch connection (if so equipped) even for short trips.

REMOVE HITCH WHEN NOT TOWING: Remove hitch from towing vehicle receiver when not towing, to prevent contamination of head sockets, reduce chance of striking hitch on driveway ramps or other objects, and minimize damage in the event of a rear-end collision.

