

INSTALLATION INSTRUCTIONS

VEHICLE	HITCH NO.
TOYOTA SEQUOIA	36302

EQUIPMENT REQUIRED:

WIRING ACCESS LOCATION: SUV7

DRILL BITS:

HITCH REQUIRES 1/2" PIN AND CLIP

WRENCHES: (TIGHTEN ALL FASTENERS WITH TORQUE WRENCH) 3/4, 7/8, 18mm

3500 LB MAX GROSS TRAILER WT
300 LB MAX TONGUE WEIGHT
DO NOT EXCEED TOWING VEHICLE RATINGS

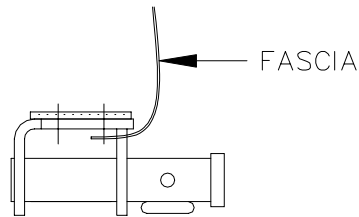

HITCH SHOWN IN PROPER POSITION

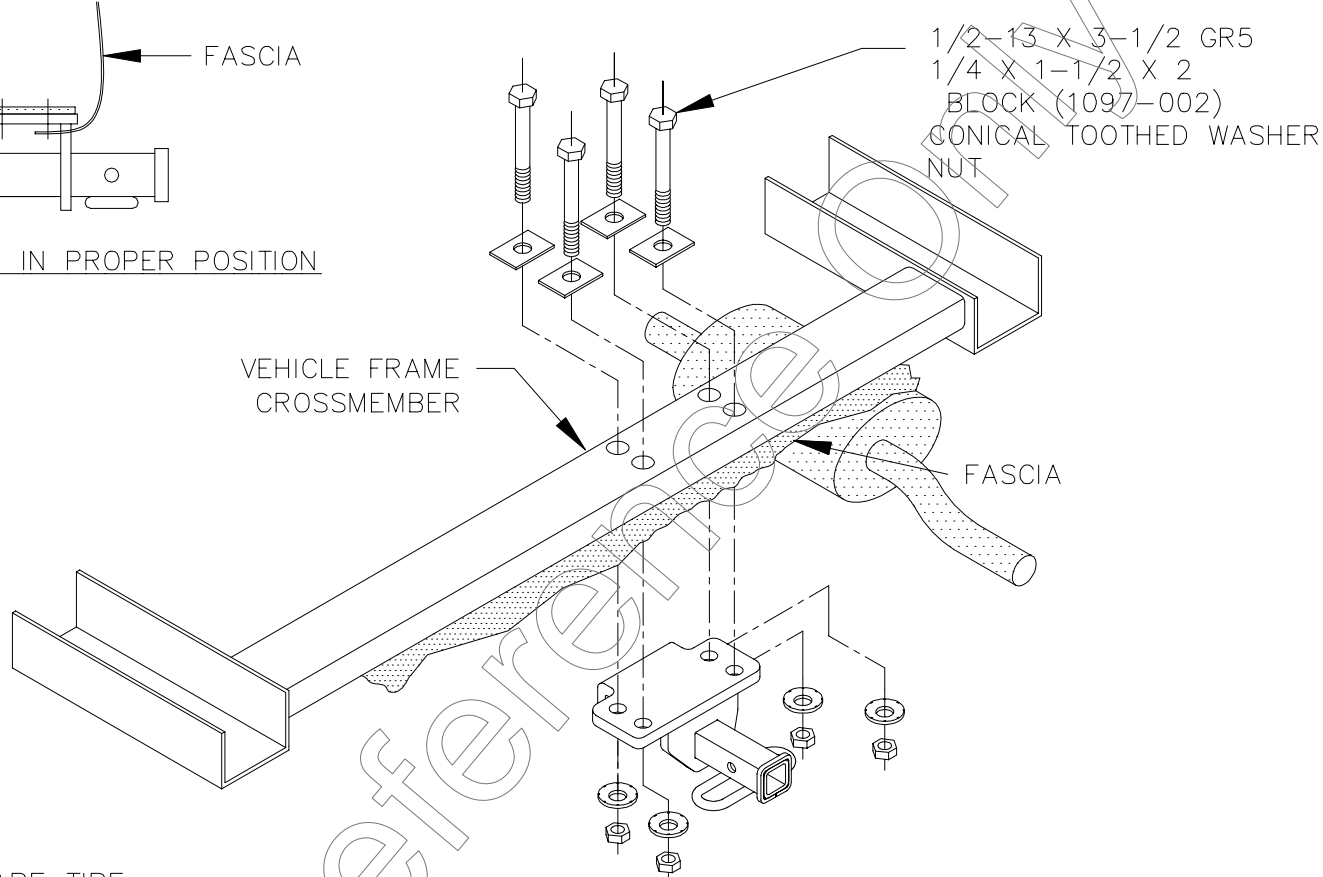

1. LOWER SPARE TIRE.
2. RAISE HITCH INTO POSITION, MAKING SURE TO SLIDE HITCH TOP PLATE UNDER FASCIA.
3. INSTALL FASTENERS AS SHOWN.
4. RAISE SPARE TIRE BACK INTO POSITION.

TIGHTEN ALL 1/2-13 GR5 FASTENERS TO 75 LB-FT.

<p>DESIGNED FOR USE WITH</p> <p>PIN 2210</p> <p>CLIP 2209</p> <p>DRAWBAR 36021 ZINC</p>	<p>DRAWBAR REPLACEMENT KIT (INCLUDES PIN & CLIP)</p> <p>36071 ZINC</p> <p>NOTE: REPLACEMENT DRAWBAR AVAILABLE ONLY IN KIT. PINS & CLIPS AVAILABLE SEPARATELY.</p>
<p>USE ONLY DRAWBAR SHOWN FOR CORRECT BUMPER CLEARANCE & HEIGHT. REMOVE DRAWBAR WHEN NOT TOWING TO PROTECT DRAWBAR OPENING IN HITCH WHEN NOT TOWING, INSERT COVER #2211 (PURCHASED SEPARATELY).</p>	

THIS PRODUCT COMPLIES WITH SAFETY SPECIFICATIONS AND REQUIREMENTS FOR CONNECTING DEVICES AND TOWING SYSTEMS OF THE STATE OF NEW YORK AND V.E.S.C. REGULATION V-5.

APPROX WEIGHT (LB.)	10	FASTENER KIT NO.	F36302
---------------------	----	------------------	--------

NOTE: Check hitch frequently, making sure all fasteners and ball are properly tightened. If hitch is removed, plug all holes in trunk pan or other body panels to prevent entry of water and exhaust fumes. A hitch or ball which has been damaged should be removed and replaced. Observe safety precautions when working beneath a vehicle and wear eye protection. Follow car maker's specs for maximum trailer weight and tongue weight. Do not cut access or attachment holes with a torch.

