

13359

97-03 FORD F-150 & F-250 LIGHT DUTY (NEW BODY STYLE)
99-CURRENT FORD F-250 & F-350 SUPER DUTY
2008 FORD F-450 SUPER DUTY

10/3/2012

FITS 20" SPARE TIRE

GROSS LOAD CAPACITY WHEN USED AS A WEIGHT CARRYING HITCH: 6,000 LBS. TRAILER WEIGHT & 600 LBS. TONGUE WEIGHT.
GROSS LOAD CAPACITY WHEN USED AS A WEIGHT DISTRIBUTION HITCH: 10,000 LBS. TRAILER WEIGHT & 1,000 LBS. TONGUE WEIGHT

*****DO NOT EXCEED VEHICLE MANUFACTURER'S RECOMMENDED TOWING CAPACITY.*****

Parts List			
ITEM	QTY	PART NUMBER	DESCRIPTION
1	6	1/2-13 x 1 3/4	CARRIAGE BOLT
2	6	CM-SP1	.250 x 1.50 x 2.00" SQUARE HOLE SPACER
3	6	HFN 1213	HEX FLANGE NUT

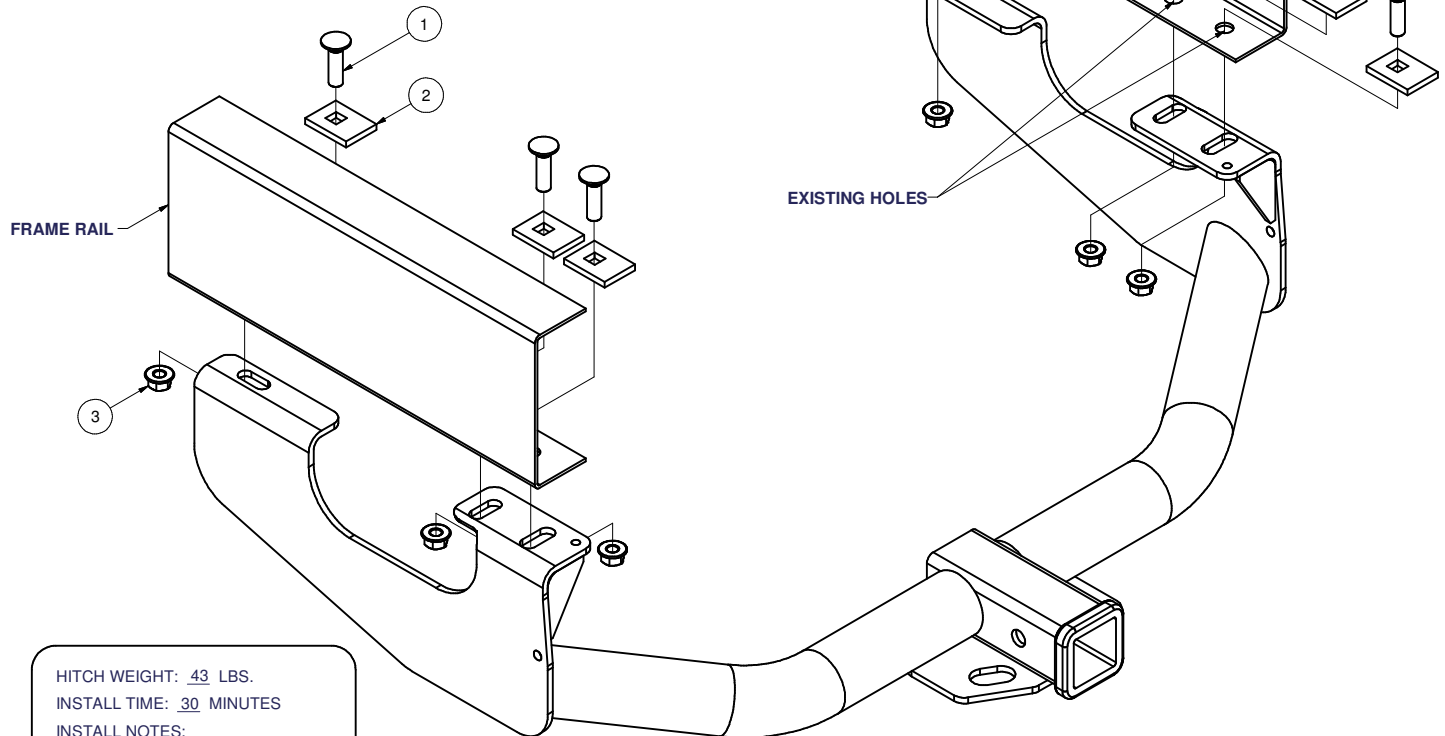
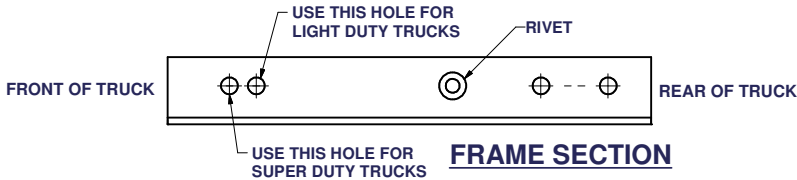

HITCH WEIGHT: 43 LBS.
INSTALL TIME: 30 MINUTES
INSTALL NOTES:
- NO DRILLING REQUIRED
- LOWER SPARE

INSTALLATION STEPS

- 1) Lower the spare tire for ease of installation. (Spare tire will be replaced after the hitch is installed.)
- 2) Install 1/2" carriage bolts and spacers through existing holes in frame as shown.
- 3) Raise hitch into position over carriage bolts and secure with flange nuts as shown. Be sure the wiring harness near the end of the truck frame is not pinched between the hitch and frame.
(Note: Only one of the two holes toward the front of the truck will be used in the side plates.)
- 4) Torque all 1/2" fasteners to 110 lb.-ft.
- 5) Raise the spare tire back into its storage location under truck.
(Note: Spare may need to be pushed toward front of truck to provide clearance between tire and hitch.)

PERIODICALLY CHECK THIS RECEIVER HITCH TO ENSURE THAT ALL FASTENERS ARE TIGHT AND THAT ALL STRUCTURAL COMPONENTS ARE SOUND.

Curt Manufacturing Inc., warrants this product to be free of defects in material and/or workmanship at the time of retail purchase by the original purchaser. If the product is found to be defective, Curt Manufacturing Inc., may repair or replace the product, at their option, when the product is returned, prepaid, with proof of purchase. Alteration to, misuse of, or improper installation of this product voids the warranty. Curt Manufacturing Inc.'s liability is limited to repair or replacement of products found to be defective, and specifically excludes liability for incidental or consequential loss or damage.